

1. Main Unit and Battery (Cordless Flare RF20S/Cordless Flange RT20S)

2021/8/6

Item No.	Part No.	Part Name	Quantity	Compatibility		Remarks
				RF20N	RT20N	
1-a	6V59	Number Sticker "REX" English CE	1	-	-	RF20S only
1-b	6V61	Number Sticker "REX" English CE	1	-	-	RT20S only
2	DF46	Tapping Screw $\phi 4 \times 15$	8	o	o	
3	DG08S	Housing A + B set	1 set	-	-	No.4-a&b
4-a	DG08	Housing A	1	-	-	to be supplied as a set No. 3
4-b	DG09	Housing B	1	-	-	to be supplied as a set No. 3
5	DG10S	Motor and First Pinion set	1set	-	-	No.6&7
6	DG10	First Pinion	1	-	-	to be supplied as a set No. 5
7	DG15	Motor	1	-	-	to be supplied as a set No. 5
8	DG19	R/L Lever	1	-	-	
9	DF40	Strap	1	o	o	
10	DG01	Battery Holder & R/L Switch set	1set	-	-	No.11&12
11	DG14	Battery Holder	1	-	-	to be supplied as a set No. 10
12	DG16	R/L Switch	1	-	-	to be supplied as a set No. 10
13	DF44	Bearing No.605	1	o	o	
14	DG11S	First Gear and Second Pinion set	1set	-	-	No.15&16
15	DG12	Second Pinion	1	-	-	to be supplied as a set No. 14
16	DG11	First Gear	1	-	-	to be supplied as a set No. 14
17	DF38	Metal A	1	o	o	
18	DF45	Bearing No.6902	1	o	o	
19	DG13S	Second Gear and Spline Holder set	1set	-	-	No.20&21
20	DF37	Spline Holder	1	o	o	to be supplied as a set No. 19
21	DG13	Second Gear	1	-	-	to be supplied as a set No. 19
22	DF39	Metal B	1	o	o	
23-a	6V62	Name Sticker "REX"	1	-	-	RF20S only
23-b	6V63	Name Sticker "REX"	1	-	-	RT20S only
24-a	-	Li-ion Battery Pack / 10.8V,1500mAh 100V-240V	1 set	-	-	No.25&26/424982 English / discontinued
24-b	-	Li-ion Battery Pack / 10.8V,2000mAh 100V-240V	1 set	-	-	No.25&26/424987 English
25-a	DG04	Li-ion Battery Pack (Without Sticker; No.26-a or b)	1	-	-	1500mAh / discontinued
25-b	DG22	Li-ion Battery Pack (Without Sticker; No.26-c or d)	1	-	-	2000mAh
26-a	6V64	Li-ion Battery Sticker Japanese	1	-	-	not for sale / 1500mAh / discontinued
26-b	6V65	Li-ion Battery Sticker English	1	-	-	not for sale / 1500mAh / discontinued
26-c	9V35	Li-ion Battery Sticker Japanese	1	-	-	not for sale / 2000mAh
26-d	9V36	Li-ion Battery Sticker English	1	-	-	not for sale / 2000mAh
27	DG02	Main Unit	1set	-	-	Without Li-ion Battery Pack; No.24

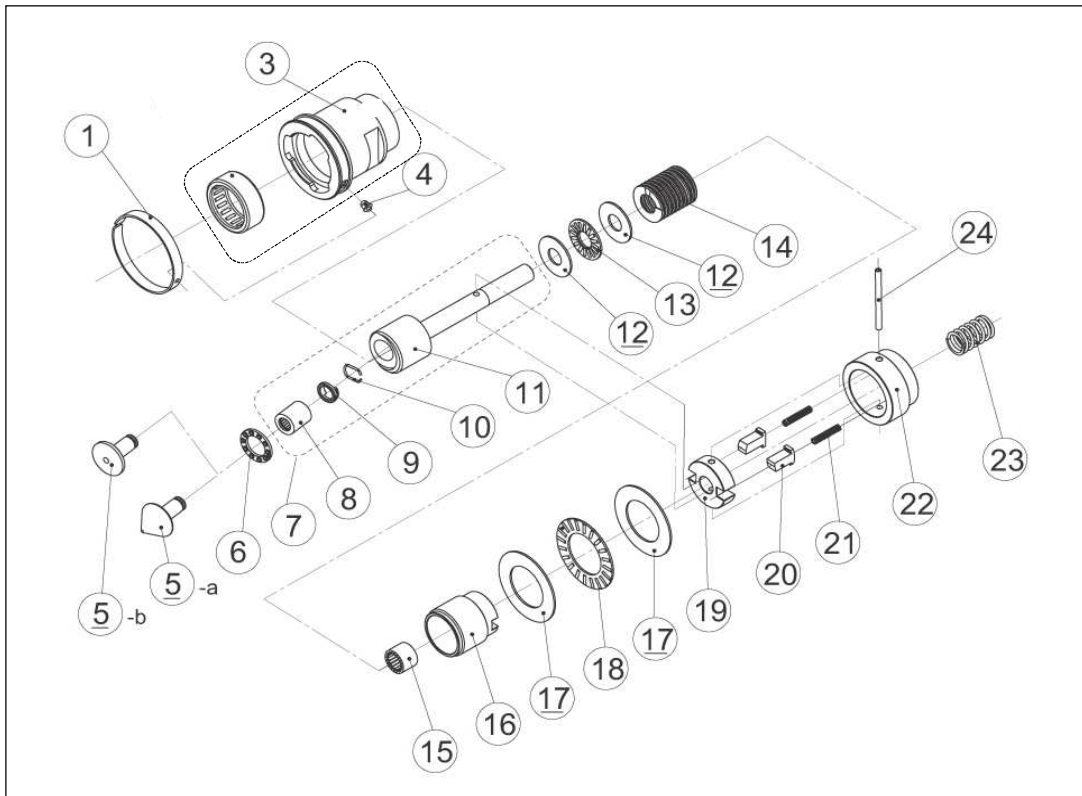

2. Flaring/Flanging Device Unit (Cordless Flare RF20S/Cordless Flange RT20S)

Item No.	Part No.	Part Name	Quantity	Compatibility		Remarks
				RF20N	RT20N	
1	DF16	Clamp Notch Spring	1	○	○	
3	DF05S	Flare Holder Set	1	○	○	included Needle Bearing/Old No. DF05
4	DF15	Clamp Notch	1	○	○	
5-a	DF14	Flare Cone	1	○		RF20S only
5-b	DB30	Flange Cone	1		○	RT20S only
6	DA32	Thrust Bearing	1	○	○	
7	DF10S	Main Shaft Set	1	○	○	No. 8, 9, 10,11 set
8	DF23	Needle Bearing*	1	○	○	to be supplied as a set No. 7
9	DA05	Spring Holder*	1	○	○	to be supplied as a set No. 7
10	DA04	Cone Spring*	1	○	○	to be supplied as a set No. 7
11	DF10	Main Shaft*	1	○	○	to be supplied as a set No. 7
12	DF25	Thrust Washer	2	○	○	
13	DF24	Needle Bearing	1	○	○	
14	DF11	Pressure Spring	1	○	○	
15	DF21	Needle Bearing	1	○	○	
16	DF30	Feed Screw	1	○	○	
17	DF27	Thrust Washer	2	○	○	
18	DF26	Needle Bearing	1	○	○	
19	DF07	Clutch Pin Holder	1	○	○	
20	DF08	Clutch Pin	2	○	○	
21	DF13	Clutch Pin Spring	2	○	○	
22	DF09	Clutch Pin Cover	1	○	○	
23	DA11	Wire Spring B	1	○	○	
24	WL3D	Spring Pin φ3x40	1	○	○	

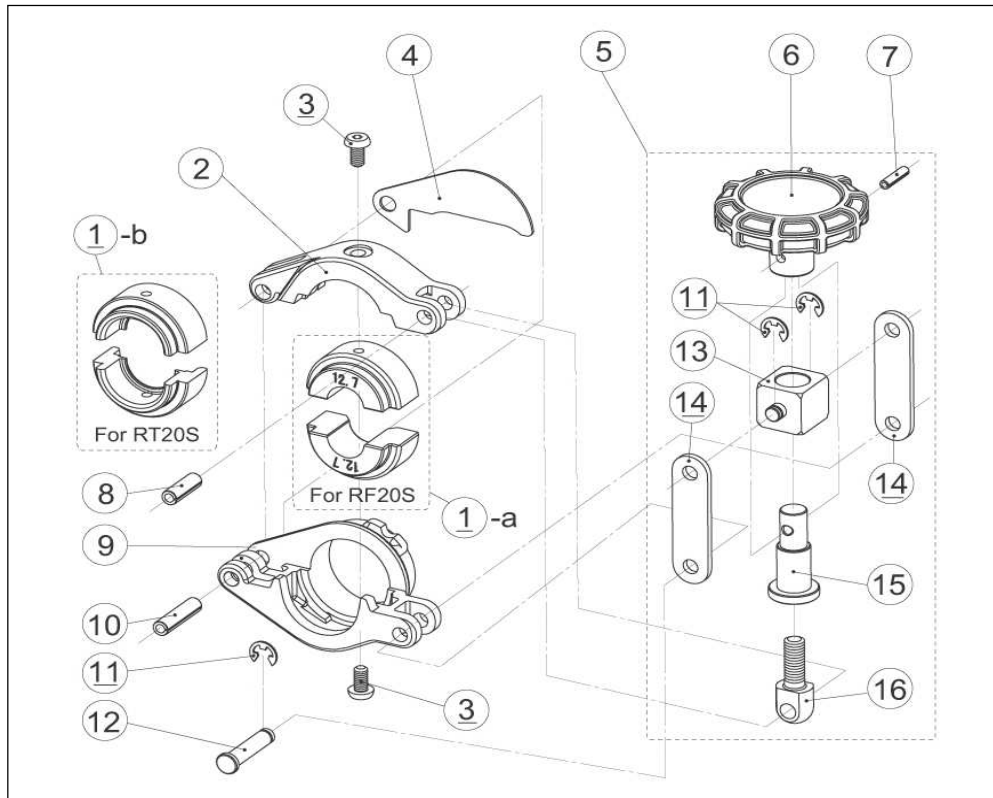

3. Clamp (Cordless Flare RF20S/Cordless Flange RT20S)

Item No.	Part No.	Part Name	Quantity	Compatibility		Remarks
				RF20N	RT20N	
1-a-1	DA9A	Liner ¼" (6.35)	2	○	-	424850/RF20S only
1-a-2	DA9B	Liner ⅜" (9.53)	2	○	-	424852/RF20S only
1-a-3	DA9C	Liner ½" (12.7)	2	○	-	424853/RF20S only
1-a-4	DA9D	Liner ⅝" (15.88)	2	○	-	424854/RF20S only
1-a-5	DA9E	Liner ¾" (19.05)	2	○	-	424855/RF20S only
1-b-1	DB02	Liner 1/2 (M-13, 16.8)	2	-	○	424777/RT20S only
1-b-2	DB03	Liner 3/4 (M-15, 20.0)	2	-	○	424778/RT20S only
2	DF52	Clamp B	1	○	○	
3	W04E	Socket Button Head Cap Screw M4×8	2	○	○	
4	DF53	Stopper Plate	1	○	-	RF20S only
5	DF60	Toggle Set	1set	○	○	
6	DF59	Knob	1	○	○	
7	WL34	Spring Pin φ3×12	1	○	○	
8	WL5C	Spring Pin φ5×15	1	○	○	
9	DF51	Clamp A	1	○	○	
10	WL54	Spring Pin φ5×20	1	○	○	
11	WY04	Retaining Ring E-type Size 4	3	○	○	
12	DF57	Clamp Pin	1	○	○	
13	DF56	Hinge Block	1	○	○	
14	DF58	Clamp Link	2	○	○	
15	DF55	Clamp Bolt Holder	1	○	○	
16	DF54	Clamp Bolt	1	○	○	

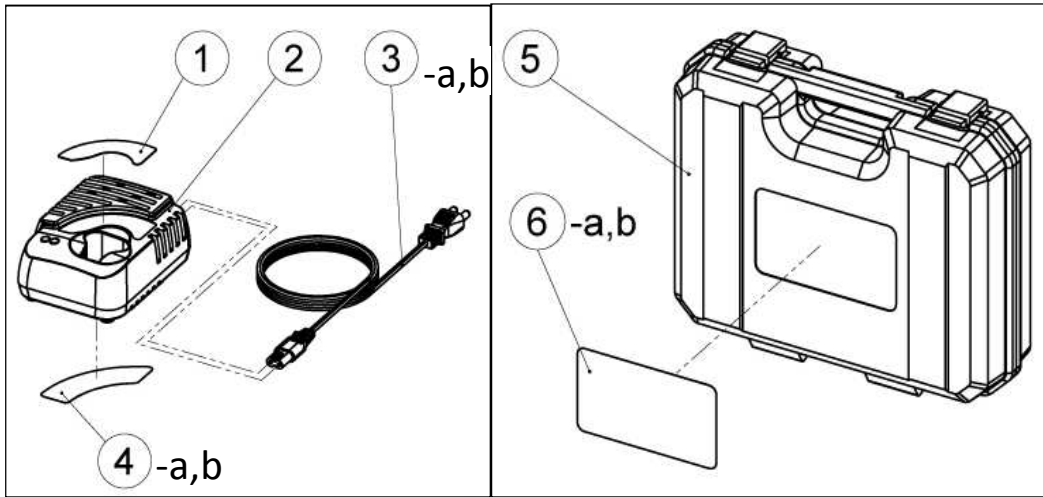

4. Charger and Case (Cordless Flare RF20S/Cordless Flange RT20S)

Item No.	Part No.	Part Name	Quantity	Compatibility		Remarks
				RF20N	RT20N	
1	DG17	Sticker for Li-ion Battery Charger 220V	1	-	-	
2	DG03	Charger for Li-ion Battery 220V	1	-	-	424981:No.1&4 Include
3-a	DG05	Power Cord 100V	1	-	-	
3-b	DG06	Power Cord 220V	1	-	-	
4-a		Rev side Sticker for Battery Charger (Japanese)	1	-	-	
4-b	6V66	Rev side Sticker for Battery Charger (English)	1	-	-	
5	DG07	Carrying Case	1	-	-	424959:No.6-a Include/424984No.6-b Include
6-a	6V58	RF20S Carrying Case Sticker "Rex"	1	-	-	424959/RF20S only
6-b	6V60	RT20S Carrying Case Sticker "Rex"	1	-	-	424984/RT20S only
-	6V51	RF20S/RT20S Operation Manual English	1	-	-	