

**REX**

COPPER TUBE TOOL

# CORDLESS FLARE RF20S

STAINLESS FLEXIBLE TUBE TOOL

# CORDLESS FLANGE RT20S

## OPERATION MANUAL

### ORIGINAL INSTRUCTIONS

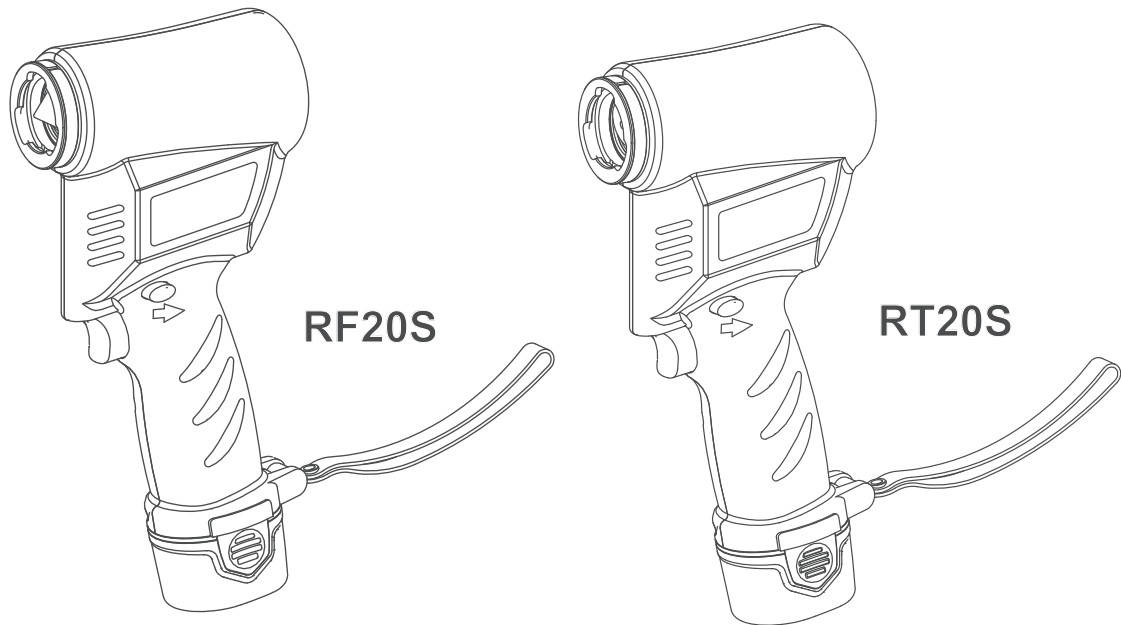

CE



Be sure to read this  
Operation Manual before  
using the product.

- Note -

- Be sure to hand this operation manual to the user.
- To ensure safe and efficient use, read the manual thoroughly before using the product.
- Be sure to keep the manual where the operator can refer to it whenever necessary.

Date of purchase:

Year

Month

Distributor:

Thank you for purchasing a REX product.

Our product will give you years of reliable service if you simply follow the instructions in this manual carefully.

Before using the product, therefore, make sure you read the manual from start to finish, paying particular attention to the Safety Considerations on pages 2 - 4 and Precautions on pages 5 - 7.

To avoid accident and injury, never use for any purposes other than those described in this manual.

Should you need further advice, contact your distributor or REX Industries Co., Ltd.

---

## CONTENTS

---

General Safety Warnings for Power Tools.....	1
Safety Considerations .....	2
Precautions for using RF20S/RT20S.....	5
Precautions for using the charger/battery.....	6
Main Parts, Specifications for RF20S .....	8
Main Parts, Specifications for RT20S .....	9
Standard Accessories, Use.....	10
Operation Guide.....	11
Getting Ready	
- Charging the battery.....	11
RF20S: Flaring copper tube	
(1) Cutting and scraping the tube.....	12
(2) Clamping the tube .....	13
(3) Flaring .....	15
(4) Removing the tube .....	16
RT20S: Flanging	
(1) Cutting flexible tube.....	17
(2) Setting the clamp .....	17
(3) Flanging .....	18
- Replacing the flaring or flanging cone .....	19
Maintenance and Care .....	20
Servicing and Repairs .....	20
Before Asking for Repairs or Servicing .....	21
-Troubleshooting (RF20S) .....	21
-Troubleshooting (RT20S) .....	22
-Troubleshooting (RF20S/RT20S) .....	22
-Troubleshooting (Charger RF20SC) .....	22
Optional Accessories for RF20S .....	23
Optional Accessories for RT20S .....	24

---

### Definitions of **▲WARNING** and **▲CAUTION**

In this operation manual, warnings are divided into **▲WARNING** and **▲CAUTION**.

**▲WARNING** : indicates actions which could possibly result in death or severe injury to the user if the product is used incorrectly.

**▲CAUTION** : indicates actions which could possibly result in injury to the user, or physical damage, if the product is used incorrectly.

Even items labelled **▲CAUTION** could have serious results under certain conditions.

Be sure to observe these warnings carefully as they greatly affect safety.

- If this operation manual is lost or damaged, you can download a copy from our website; <http://www.rexind.co.jp>

- Parts and specifications are subject to change without prior notice, due to improvements in quality, performance or safety standards. In such cases, the contents, photographs, illustrations etc. in this manual may be different to the product you have purchased.

---

# General Safety Warnings for Power Tools

## WARNING

**Read all safety warnings and all instructions.** Failure to follow the warnings and instructions may result in electric shock, fire and/or serious injury. **Save all warnings and instructions for future reference!** The term "power tool" in the warnings refers to your mains-operated (corded) power tool or battery-operated (cordless) power tool.

### 1. Work area safety.

- Keep the work area clean and well lit. Cluttered or dark areas invite accidents.
- Do not operate power tools in explosive atmospheres, such as in the presence of flammable liquids, gases or dust. Power tools create sparks which may ignite the dust or fumes.
- Keep children and bystanders away while operating a power tool. Distractions can cause you to lose control.

### 2. Electrical safety

- Power tool plugs must match the outlet. Never modify the plug in any way. Do not use any adapter plugs with earthed (grounded) power tools. Unmodified plugs and matching outlets will reduce risk of electric shock.
- Avoid body contact with earthed or grounded surfaces, such as pipes, radiators, ranges and refrigerators. There is an increased risk of electric shock if your body is earthed or grounded.
- Do not expose power tools to rain or wet conditions. Water entering a power tool will increase the risk of electric shock.
- Do not mistreat the cord. Never use the cord for carrying, pulling or unplugging the power tool. Keep the cord away from heat, oil, sharp edges or moving parts. Damaged or entangled cords increase the risk of electric shock.
- When operating a power tool outdoors, use an extension cord suitable for outdoor use. Using a cord suitable for outdoor use reduces the risk of electric shock.
- If operating a power tool in a damp location is unavoidable, use a residual current device (RCD) protected supply. Use of an RCD reduces the risk of electric shock.

### 3. Personal safety.

- Stay alert, watch what you are doing and use common sense when operating a power tool. Do not use a power tool while you are tired or under the influence of drugs, alcohol or medication. A moment of inattention while operating power tools may result in serious personal injury.
- Use personal protective equipment. Always wear eye protection. Protective equipment such as a dust mask, non-skid safety shoes, hard hat, or hearing protection used for appropriate conditions will reduce personal injuries.
- Prevent the product from starting up unintentionally or unexpectedly. Ensure the switch is in the off-position before connecting to a power source and/or battery pack, picking up or carrying the tool. Carrying power tools with your finger on the switch or energising power tools that have the switch turned on invites accidents.
- Remove any adjusting key or wrench before turning the power tool on. A wrench or a key left attached to a rotating part of the power tool may result in personal injury.
- Do not overreach. Keep proper footing and balance at all times. This enables better control of the power tool in unexpected situations.
- Dress appropriately. Do not wear loose clothing or jewellery. Keep your hair, clothing and gloves away from moving parts. Loose clothes, jewellery or long hair can be caught in moving parts.
- If devices are provided for the connection of dust extraction and collection equipment, ensure these are connected and properly used. Use of dust collectors can reduce dust-related hazards.

### 4. Power tool use and care.

- Do not force the power tool. Use the correct power tool for your application. The correct power tool will do the job better and safer at the rate for which it was designed.
- Do not use the power tool if the switch does not turn it on and off. Any power tool that cannot be controlled with the switch is dangerous and must be repaired.
- Disconnect the plug from the power source and/or the battery pack from the power tool before making any adjustments, changing accessories, or storing power tools. Such preventive safety measures reduce the risk of starting the power tool accidentally.
- Store idle power tools out of the reach of children and do not allow persons unfamiliar with the power tool or these instructions to operate power tool. Power tools are dangerous in the hands of untrained users.
- Maintain power tools regularly. Check for misalignment or jamming of moving parts, breakage of parts and any other condition that may affect the power tool's operation. If damaged, have it repaired before use. Many accidents are caused by poor maintainance.

# General Safety Warnings for Power Tools

## WARNING

- Keep cutting tools sharp and clean. Properly maintained cutting tools with sharp cutting edges are less likely to jam and are easier to control.
- Use the power tool, accessories and tool bits etc. in accordance with these instructions, taking into account the working conditions and the work to be performed. Using the product for anything other than its intended use can result in a hazardous situation.

### 5. Battery tool use and care.

- Recharge only with the charger specified by the manufacturer. A charger that is suitable for one type of battery pack may create a risk of fire when used with another battery pack.
- Use power tools only with specifically designated battery packs. Use of any other battery packs may create a risk of injury and fire.
- When the battery pack is not in use, keep it away from other metal objects such as paper clips, coins, keys, nails, screws or other small metal objects that can make a connection from one terminal to another. Shorting the battery terminals together may cause burns or a fire.
- Under extreme conditions, fluid may leak from the battery; avoid contact. If you do accidentally come into contact with the fluid, flush with water. If battery fluid contacts the eyes, seek medical help immediately. Fluid that leaks from the battery may cause irritation or burn you.

### 6. Servicing

- Have your power tool serviced by a qualified repair professional, using only identical replacement parts. This will ensure that the safety of the power tool is maintained.

## Safety Considerations

## WARNING

### 1. Ensure you use the correct voltage.

- Be sure to use the voltage indicated on the name plate of the main unit or in the operation manual. Using the product at a voltage different from that indicated can result in overheating, smoke or fire.

### 2. Check the switch is OFF before inserting the plug into the power supply socket.

- If the plug is inserted into the power supply when the switch is ON, the product may start operating abruptly and is liable to cause accidents. Be sure to check the switch is OFF.

### 3. Be sure to avoid electric shock.

- Do not touch the plug with wet hands.
- Do not use the product in rain or in places where moisture can easily get into it.
- Be sure to ground the product to avoid electric shock.

### 4. Take notice of conditions at the work site.

- Do not use the product in rain, humid or damp places, or places where moisture can easily get into it. Humidity will lower insulation of the motor and cause electric shock.
- Do not use close to flammable fluids or gases, such as gasoline and thinner. Doing so could result in fire or explosion.
- Do not install, charge, or use the product in a humid or wet place, nor expose it to rain or snow. Doing so may cause electric shock or injury.
- Do not install, charge, use or leave the product in a hot place such as near a fire or under the scorching sun. Doing so may result in overheating, smoke, or fire.

### 5. Use designated accessories and attachments.

- Do not use accessories and attachments other than those designated in the operation manual or our catalogues. Doing so may result in accidents or injuries.

## WARNING

### **6. In the following cases, turn the product OFF and pull the plug out of the power supply socket.**

- When the product is not in use or parts are changed, repaired, cleaned or inspected.
  - When accessories are changed.
  - When hazards are expected (including electric power failure).
- If the product is plugged in, it may start operating unexpectedly, causing accidents.

### **7. If any abnormality is noticed, stop operating the product immediately.**

- If the product does not operate smoothly, or abnormalities such as unusual odours, vibration or noise are detected, stop operating it immediately.
- For safe and efficient operation, maintain the machine and keep it at its full potential. Using a machine that is not fully operational may cause injury.
- Check symptoms against the items in the section entitled, "Troubleshooting" at the end of this manual and observe the corresponding instructions.  
Using the product continuously may result in overheating, smoke or fire, causing accident or injury.
- If it overheats or smoke is detected, do not attempt an overhaul yourself but ask for an inspection and repair.
- Be careful not to shake, drop or forcefully impact the body of the tool as it has a built-in precision mechanism. Doing so may affect the product's operation.

### **8. Keep the work site clean.**

- Ensure you keep worktables and the work site in good order and well lit.
- A cluttered site and work table are liable to cause accidents.

### **9. Do not let unauthorised personnel near the product.**

- Do not let anyone other than authorised personnel touch the product or the power cord.
- Do not let anyone other than authorised personnel enter the work site, especially children. Doing so may lead to injury.

### **10. Do not apply excessive force when using the product.**

- To ensure safe and efficient operation, use within the capacity of the product.  
Applying force may not only damage the product but could also result in accident or injury.
- Do not use the product in any way that could cause the motor to lock, or cause smoke or fire.

### **11. Use the flaring/flanging tool only for its designated purpose.**

- Do not use the product on tubes not specified in this manual. Using the product for any purpose other than flaring/flanging tubes, such as fastening the tube to a joint etc., will not only damage the product and/or motor but could also lead to accident or injury.

### **12. Wear appropriate clothing.**

- Do not wear loose or loose-sleeved clothing, ties, jewellery such as necklaces, knitted gloves or scarves.  
Do up all buttons, fasteners, etc. on the clothing you are wearing before starting work. Otherwise, you could get caught in the rotating parts, resulting in serious accident or injury.
- When working outdoors, it is recommended that you wear rubber gloves and non-slip shoes.  
Slippery gloves and shoes are liable to cause injuries.
- Wear safety caps, safety shoes, safety glasses, dust masks, protective noise-reduction equipment etc. according to the working environment.
- Do not wear scarves, and cover long hair with caps or hair nets to prevent them getting caught in rotating parts.

### **13. Do not work in an unnatural posture.**

- Keep a firm footing and balance to avoid falling over and injuring yourself.

### **14. Remove tools used for inspection such as wrenches.**

- Before turning the switch ON, check that tools used for inspection and adjustment have been removed.  
Failure to pay attention to this may result in an accident or injury.

# Safety Considerations

## WARNING

### **15. Operate the product with great care.**

- Always pay great attention to how you handle and operate the product and to the surrounding conditions. Carelessness may result in accident or injury.
- Do not operate the product when concentration is lowered such as when tired, after drinking alcohol, when sick, or affected by medication, etc.
- Use common sense. Irrational behaviour can cause accidents and injuries.

### **16. Do not handle the power cord carelessly.**

- Do not carry the product by the cord, or pull the plug out of the socket with the cord.
- Do not place the cord near heated objects, fats & oils, or cutters and other objects with sharp edges.
- Take care not to tread on the cord, pull the cord or apply unnecessary force resulting in damage to the cord. Electric shock or short-circuit may occur, causing fire.

### **17. Perform careful maintenance daily.**

- When changing accessories and parts, follow the operation manual carefully.
- Keep parts used for gripping the product dry and clean, and free of oil and grease. If oil or grease remains on the product, it may slip and cause injury.
- Periodically inspect the power supply cord and plug. If damaged, ask the store where you bought them or a REX distributor for repairs. If you leave them as is, you may get an electric shock, or a short circuit may cause a fire.
- If an extension cord is used, inspect the cord periodically and, if damaged, replace it. If you leave as is, there is a danger of electric shock, short circuit or fire.
- If extension cords are used outdoors, use extension cords designed for outdoor use to prevent electric shock, short-circuit or fire.

### **18. Check for damaged parts.**

- Before using the product, carefully inspect the external appearance of the product and other parts for damage, and make sure that it operates normally and can perform its intended functions.
- Inspect the product for any abnormalities such as in adjustment of movable parts, tightening, damage to parts, etc.
- Check the adjustment position of moving parts, tightening, damage to parts, installation and any other abnormalities.
- When replacing or repairing broken parts, follow the operation manual. If no instructions are specified in the operation manual, ask the store where you bought the product or a REX distributor for repairs.
- Do not use the power cord or plug if damaged. If you leave them as is, there is a danger of electric shock, short circuit or fire. Ask the store where you bought the product or a REX distributor for repairs.
- Do not use if the Stop and Start switch does not work properly.

### **19. Store carefully when not in use.**

- Store in a dry place away from children and locked with a key.

### **20. For overhaul and repair, ask an appointed REX agent.**

- Our products comply with corresponding safety standards. Do not remodel.
- Be sure to ask the store where you bought them or a REX distributor for any repairs. If repairs are carried out by unskilled or unqualified personnel, the product's performance will be adversely affected, which may result in accident or injury.

### **21. Fix the object to be processed securely.**

- Fix the object to be processed securely. If it isn't, it will not be processed correctly and may cause an accident or injury.

# Precautions for using RF20S/RT20S

## WARNING

### 1. Hold securely!

- When you switch on and the flare cone starts rotating, the hand you hold the product with may be jarred; take care not to hit any objects around you.
- NOTE: Do not keep the trigger fixed in position deliberately.

### 2. Take care when working in high places!

- When working high up, make sure that there is nobody below you.  
If anything falls down, it may cause an accident or injury.

### 3. Avoid letting the product start up unexpectedly!

- Do not carry the product with your finger on the trigger. The product may suddenly start up causing an injury.

### 4. Install the battery securely!

- If it is not secure, the storage battery may fall out and cause an injury.

### 5. Pay attention to the time it takes to process the flare!

- When the flare is processed, the clutch makes a rattling sound.  
Release the trigger within 2 to 3 seconds after you hear the sound.  
If the processing time is prolonged, the flare may become thinner, resulting in insufficient adhesion with the joint, which may cause leakage. See also P14 of this operation manual.

## CAUTION

1. The flanging tool RT20S is designed exclusively for making flanges on SUS304, SUS316L flexible stainless steel water tubes. Do not use for any other purpose.
2. Use for water tubes only. Never use for paraffin or gas tubing.
3. Make sure clamps and tubes are mounted securely or else they could come apart, resulting in accident or injury.

# Precautions for using the charger/battery

## WARNING

### 1. The charger is for exclusive use with REX original products only!

- When charging the battery, use the exclusive battery charger only and none other.  
Never use the charger for any other rechargeable tool or battery.  
The use of any other combination of battery and charger can be dangerous. Never do so.

### 2. When charging, do not use transformers such as a booster or the like!

- Doing so will damage the charger. Use an electrical supply of the specified stated voltage only.

### 3. Cannot be used with a generator or with direct current!

- Never use with a generator or with direct current. Doing so may cause a fire, which will damage the charger.

### 4. Always charge indoors!

- Take care to prevent the battery and charger from getting wet; always charge indoors.
- Keep away from fire.
- Do not use near inflammable materials.
- When charging, the battery and charger may get fairly hot; keep out of direct sunlight and charge in a well-ventilated room.

### 5. Humidity can lead to accidents!

- Do not use in the rain, in humid conditions, or where it is wet. Humidity can result in an electric shock.  
Humidity should also be avoided as it can weaken the charger or the motor's insulation.

# Precautions for using the charger/battery

## WARNING

### **6. When charging is complete, remove the battery and pull out the plug!**

- When charging is complete, remove the battery from the charger and remove the plug from the mains. Also, be sure to remove the plug if there is a power cut.

### **7. Charge within a range of 10 to 40°C!**

- The charger has a special circuit for rapid charging - approx. 1 hour, it should be used within an ambient temperature of between 10 and 40°C. The battery's built-in protection system does not allow charging outside this range.

### **8. Do not use the same charger continuously!**

- Using the same charger continuously can cause it to overheat, resulting in an accident. After use, remove the plug and allow the charger to cool down for approximately 15 minutes before using again.
- When charging twice in a row, allow the charger to rest for more than 15 minutes to cool down before charging again. When charging 3 or more times consecutively, allow to rest for more than 1 hour and then charge again when the charger has cooled down.

### **9. Do not charge the battery straight after a rapid discharge!**

- Even after placing in the charger, the red LED may flash on and off slowly indicating that it is not yet possible to charge, or fully charge, a battery that is still hot after continuous use, etc. Wait until the battery has cooled down before charging again.

### **10. Do not charge for more than 2 hours!**

- If the green LED does not start blinking after charging for about 2 hours stop charging; the LED might possibly be malfunctioning.

### **11. Charge every 3 to 6 months!**

- Even if you do not use the battery for a while, we recommend charging it every 3 to 6 months to prevent over discharge.

### **12. Do not keep fully charged for long periods of time!**

- If you keep the battery for a long period, every 3 to 6 months store it at normal temperature and 40 to 80% charged. Be sure to remove the battery from the unit or the charger.

### **13. Never insert any foreign object into the battery slot in the charger!**

- There are terminals located inside the slot. If you insert metal, water or other foreign objects into the slot, it will cause a short and cause the charger to break down.

### **14. Do not disassemble the charger or battery!**

- Never disassemble the battery; it contains a special built-in device for rapid charging - approx. 1 hour. You will damage the unit if you try to disassemble it.
- The charger has a built-in condenser and other electronic parts; disassembling the unit will lead to electrical shock and damage.
- If either the charger or battery unit does not function properly, do not disassemble to attempt a repair yourself. Always return to the store where you bought them or to a REX distributor for repair.

### **15. Do not short circuit the battery!**

- The battery has a very low internal resistance. If it shorts, there will be high current and the unit will overheat resulting in it burning or breaking down.

### **16. Never throw a battery in a fire!**

- If you throw a battery in a fire, it may explode. Do not throw in a fire, incinerator or the like.

### **17. Do not insert any foreign body into the air vents in the charger!**

- If anything metallic or any inflammable material gets into the vents, it can cause an electric shock and damage the unit. Use in as dust-free a location as possible.



# Precautions for using the charger/battery

## WARNING

### **18. If any abnormality arises, stop charging at once!**

- If you notice any abnormality such as overheating or an unusual smell, stop charging immediately and send the unit for repair.

### **19. Take care when storing the charger!**

- Always store where the ambient temperature is under 40°C, and out of the reach of children.
- Store in a dry place away from the rain so as to reduce deterioration of the unit's insulation and to prevent electric shock.

### **20. Recycling Lithium-ion batteries you no longer need**

- Never throw away unwanted lithium-ion batteries together with ordinary household garbage. Wrap the terminals in insulating tape to prevent a short, and dispose of in accordance with local laws and regulations governing such items.

### **21. Product Shipping Notice!**

- If this product is to be transported by sea as a non-hazardous material, it must comply with SP188 of the "UN Recommendations on the Transport of Dangerous Goods". Contact your shipping company for details.

### **22. To prevent the charger and battery from emitting smoking, overheating, igniting or the battery fluid leaking, always comply with the following:**

- a) Do not use the charger or battery if they have been dropped or have undergone a hard impact.
- b) Do not allow metal objects and the like to come into contact with the terminals.
- c) When storing the units, keep them away from metal objects (screws, nails, coins etc.).
- d) Do not leave, charge or use the charger or battery near a fire, under strong sunlight, or where the temperature is very high.
- e) Do not use a battery if it has visible external damage or has become deformed.
- f) Never place in a microwave oven or high pressure vessel; do not expose to high temperatures or pressure.

### **23. If you think something is wrong, stop immediately.**

- If the battery fluid is leaking or you notice a bad smell, immediately keep away from any nearby fire or source of heat.
- While using, charging or even storing the battery, if you notice any bad smell, overheating, change of colour or shape, or any other abnormality you have not seen before, remove it from the tool or charger immediately.
- If any leaked battery fluid gets in your eyes, do not rub your eyes with your hands. Immediately wash with clean tap water, and then go directly to the doctor's for treatment. Failure to do so could lead to serious damage to your eyes.
- If any leaked battery fluid gets on your skin or clothing, wash with clean tap water immediately. Such discharge can cause severe skin irritation.

### **24. Cautions when charging the battery.**

- The battery is not charged when you purchase the product, so you will need to charge it. Sometimes, it may be difficult to fully charge a new battery, or one that has not been used for a long time. In such cases, repeat charging and discharging the battery a few times to restore it to its full capacity.
- The battery will be hot immediately after using the tool. Leave it to cool for a little before recharging.
- If the red LED goes out straight after you start charging, remove the battery from the charger, wait until the temperature is within a range of 10 to 40°C and start again. This is the range within which the battery can be charged. If it still doesn't work after several attempts, then it means that the battery has reached the end of its life or is out of order.
- If you charge the battery outside the 10 to 40°C range, the red LED will flash on and off indicating the battery cannot be charged. However, the charger will start charging automatically once the battery is within the correct temperature range.

# Main Parts, Specifications for RF20S

## Main Parts

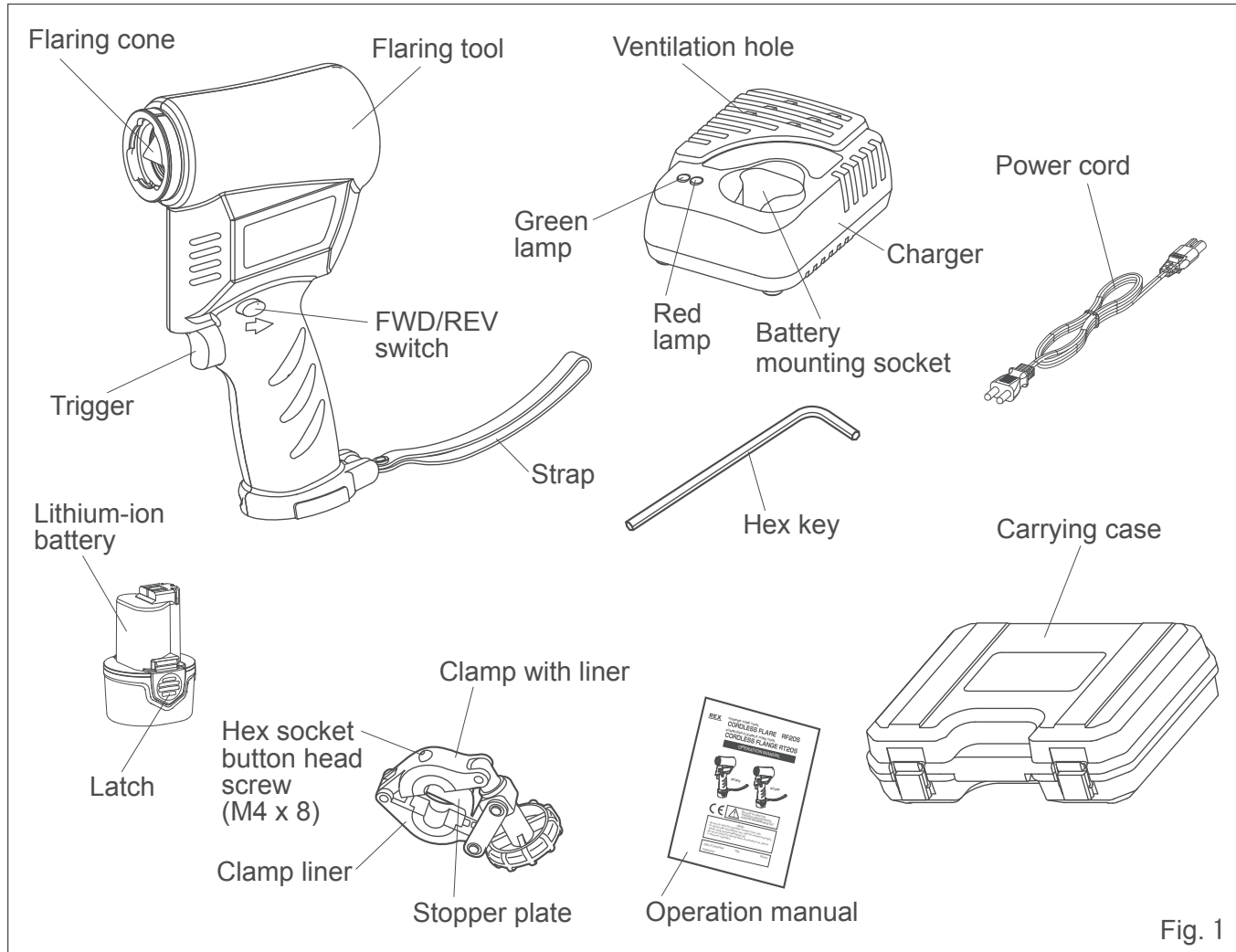

Fig. 1

## Specifications (Flaring tool RF20S)

Applicable tube	Copper tube (O/OL material) JIS H 3300 C1220T					
Applicable tube size	Nominal diameter	1/4"	3/8"	1/2"	5/8"***	3/4"***
	Outer diameter (mm)	6.35	9.52	12.70	15.88	19.05
Flare	Supports Class 2 refrigerant (Supports R410A, R32) Complies with shapes described in JIS B 8607. (Referred to elsewhere.)					
Processing method	Eccentric cone (constant-pressure plunge rotation)					
Switches	Stepless speed control trigger and FWD/REV switch					
Cone speed	0 - 280/min <sup>-1</sup> (rpm)					
Power	DC motor					
Potential No. of flares	1/2": Approx. 100 tube ends per fully charged battery. (May vary depending on usage.)					
Processing time	Approx. 5 sec.					
Vibration*	0.667 m/s <sup>2</sup>					
Uncertainty (K)*	1.5 m/s <sup>2</sup>					

\*Warning: The vibration emission during actual use of the power tool can differ from the declared total value depending on the ways in which the tool is used.

\*\*May be sold separately.

Table 1

# Main Parts, Specifications for RT20S

## Main Parts

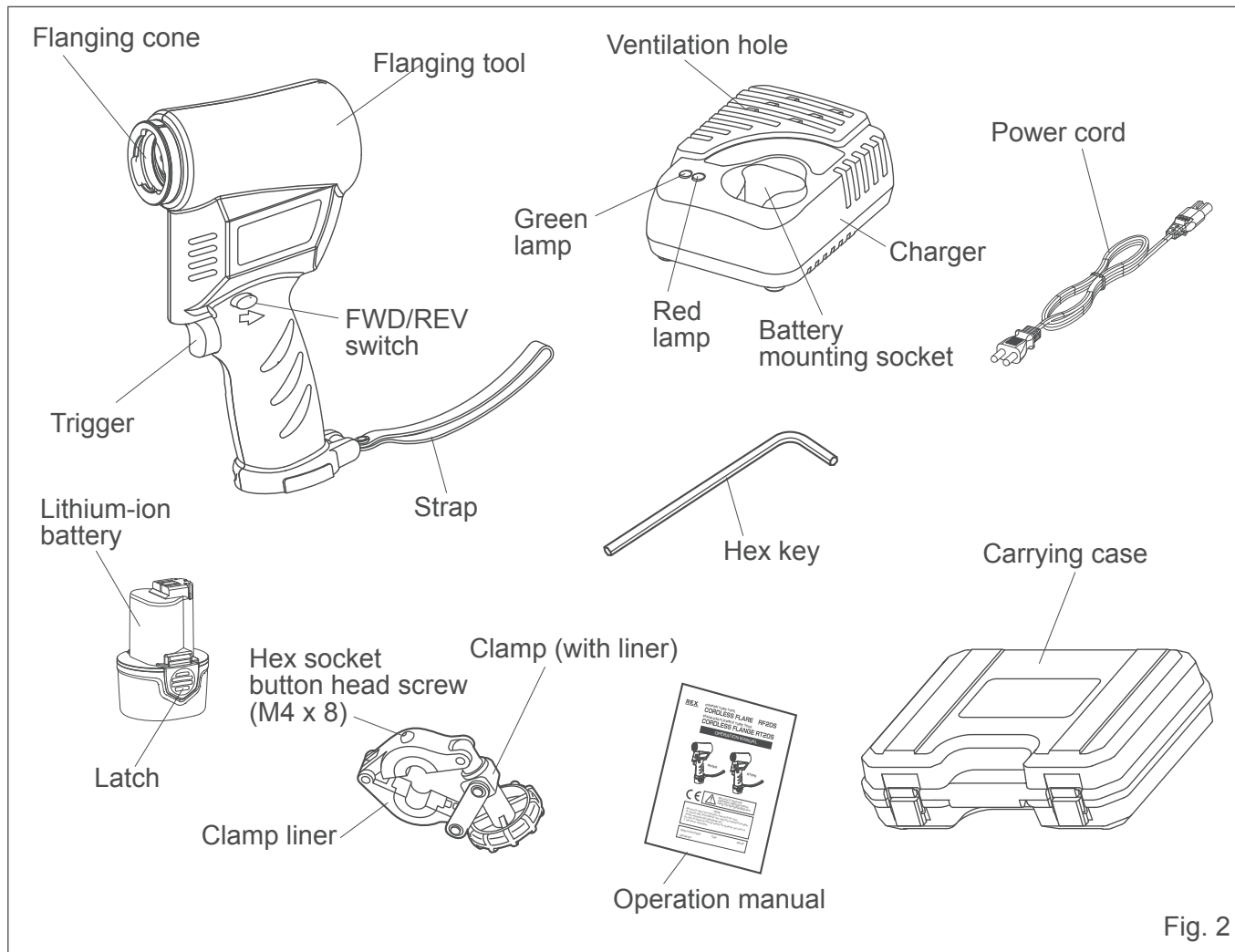

Fig. 2

## Specifications (Flanging tool RT20S)

Applicable tube	Flexible stainless steel water tube SUS304, SUS316L (for mains water supply)
Applicable tube size	M-13 (1/2") Outer diameter 16.7- 16.8mm M-15 (3/4") Outer diameter 20mm
No. of flange threads	2 or 3 threads
Processing method	Eccentric cone (constant-pressure plunge rotation)
Switches	Stepless speed control trigger and FWD/REV switch
Cone speed(min <sup>-1</sup> /rpm)	0 - 280/min <sup>-1</sup> (rpm)
Power	DC motor
Potential No. of flanges	3/4" (3 threads): Approx. 100 tube ends per fully charged battery. (May vary depending on usage.)
Processing time	Approx. 5 sec.
Vibration*	0.667 m/s <sup>2</sup>
Uncertainty(K)*	1.5 m/s <sup>2</sup>

\*Warning: The vibration emission during actual use of the power tool can differ from the declared total value depending on the ways in which the tool is used.

Table 2

## Standard Accessories, Use (For RF20S/RT20S)



Sound pressure level at operator's position	81.5 dB (A)
Noise level	92.5 dB (A)
Uncertainty (K)	3 dB

Table 3

### Battery : Model RB20SB

Battery type	Lithium-ion battery
Voltage	DC 10.8 V
Capacity	1500 mAh
Charging time	Approx. 60 minutes (depending on use) * Charge is approx. 80% complete in first 30 min.
No. of recharges	Approx. 500 times (depending on use)
Chargable temperature	0 - 40°C
Circuit protector	Over-discharge protection (Discharging stops when any one cell is reduced to 2.5 V) Temperature protection (Battery cannot be charged below 0°C or above 40°C.)

Table 4

### Charger : Model RB20SC

Battery type	REX Lithium-ion battery RF20SB (No. 424982)
Voltage	AC100 - 240 V (50/60Hz) 60 VA
Charging system	Constant current and constant voltage system
Charging voltage	DC 10.8V
Charging current	2000 mA
Chargable temperature	0 - 40°C
Circuit protector	Overcharge protection (4.25 V/cell) Overcurrent protection (7A fuse)

Table 5

## Standard Accessories (Size / Weight)

	Name	Size (W x D x H mm)	Weight(kg)	Qty.
1	RF20S Flaring/RT20S Flanging tool	131 × 66 × 230 (131 × 66 × 264)* *with batteries inserted	1,220 (1,405)	1
2	Battery	60 × 54 × 85	185	1
3	Charger (without power supply cord)	146 × 109 × 61	335	1
4	Power cord	2000 (cord length)	85	1
5	Clamp (with 1/4" liner)	84 × 84 × 45	Approx. 350	1
6	Clamp (with 3/8" liner) *RF20S only			1
7	Clamp (with 1/2" liner)			1
8	Carrying case	440 × 366 × 113	1,600	1
9	Hex key (Diameter: 2.5 mm)	18 × 63 × 3	4	1
10	Operation Manual	210 × 145 × 2	30	1

Table 6

## Use

- RF20S: Flaring copper tube. Flanging flexible stainless steel tube. (requires flanging tool set 424980 sold separately; refer to Page 23, Fig. 43).
- RT20S: Flanging flexible stainless steel tube.

## Getting Ready:

### Charging the battery

1. Remove the battery from the main unit by pressing the latch on the battery. (Fig. 3)

#### ⚠ CAUTION

- Hold the main unit firmly and remove the battery.
- Charge the battery once the tool starts to lose power.

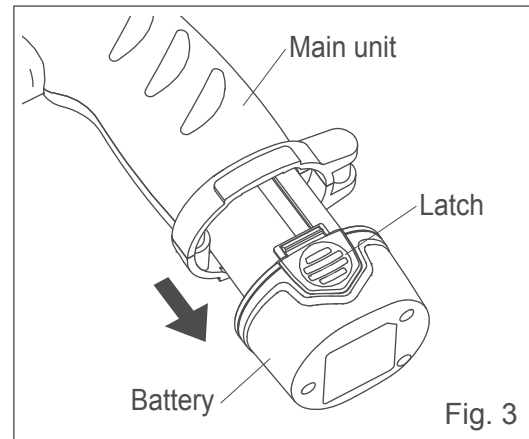

Fig. 3

2. Connect the power cord and charger, and then insert the plug into the mains. Check that the green lamp is slowly flashing on and off. This indicates that the battery is being charged. (Fig. 4)

#### ⚠ CAUTION

- Note: The input voltage is AC100 - 240 V (50/60Hz).
- Do not use a generator to charge the battery.
- Do not carry the charger with the power cord; it may drop off.

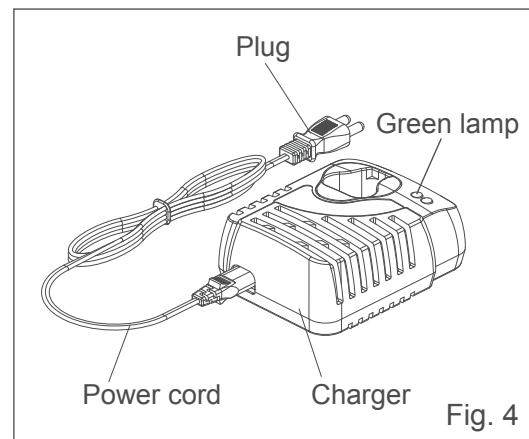

Fig. 4

3. Insert the battery as far as it will go into the mounting on the charger. (Fig. 5)

The red lamp indicates that charging has started.

After approximately 30 minutes, the green lamp starts flashing on and off quickly (indicating it is 80% charged).

The battery is fully charged when the lamp stops flashing but remains on. A full charge takes about 60 minutes in total. (Fig. 5)

You can check the status of the battery and charger from the red and green lamps. (Table 7)

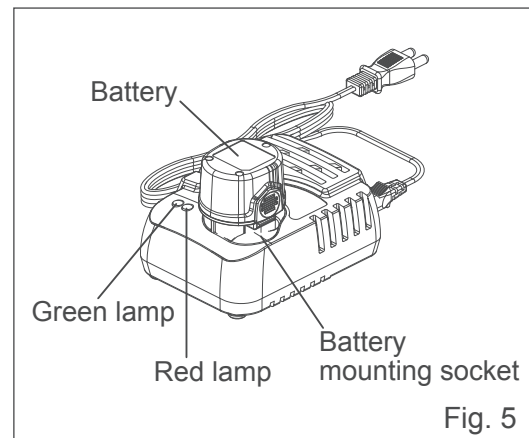

Fig. 5

Mark	Green lamp	Red lamp	Charger status
	Flashes slowly	Off	Chargeable
	Off	On	Charges the battery 0 - 80% of its capacity (about 30 minutes)
	Flashes quickly	Off	Charges the battery 80 - 100% of its capacity (about 30 minutes)
	On	Off	Fully charged
	Off	Flashes slowly	The temperature of the battery is outside the chargeable range (below 0°C, or above 40°C)
	On	On	Unable to charge (Defective battery etc.)

Table 7

# Operation Guide (For RF20S/RT20S)

## ⚠ CAUTION

- Ensure the battery is attached the correct way round.
- Charge in a place where the temperature is within the chargeable range of 10°C to 40°C. If you charge outside this range, it may degrade the performance and life of the battery and may even cause a leakage or generate excessive heat.
- The battery or the charger may get slightly hot during charging; choose a dry and well-ventilated place that is not exposed to direct sunlight.
- If you intend to charge another battery, leave the charger to cool for at least 15 minutes before charging the next one.
- If the temperature of the battery is below 10°C or above 40°C, you cannot charge it.

4. Remove the battery from the charger, and then attach it to the main unit. (Fig. 6)

## ⚠ CAUTION

- If the battery cannot be fully charged even after following the correct procedure, the battery may be dead. Attempting to charge a dead battery may damage the charger.

# Operation Guide (Flaring copper tube)

## (1) Cutting and scraping the tube

1. Mark a line where you wish to cut the tube, and then place the tube on the cutter. (Fig. 7)
  - \* Tighten the cutter so that the blade lightly presses against the tube.
  - \* Cut the tube where it is least flat or bent. Tubes that are flat or have lots of bends will affect the flare.
2. From where the cutter blade is placed on the tube, turn the knob  $\frac{1}{4}$  of a turn in the direction of A in the diagram and then rotate the unit 2 or 3 times back and forth through 90°. Then score the tube by turning the unit one full rotation around the tube to make a mark for cutting. (Fig. 8)
3. When feeding the cutter blade, the knob should be turned slowly at a rate of approximately 3 to 4 rotations of the tube cutter. (Fig. 9)

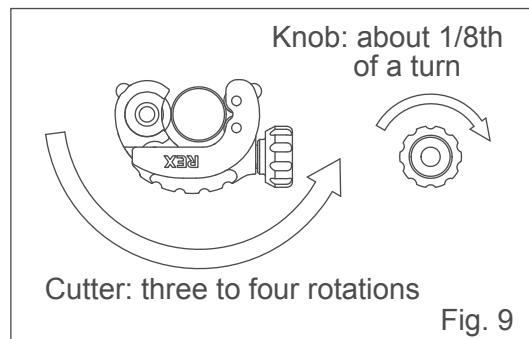
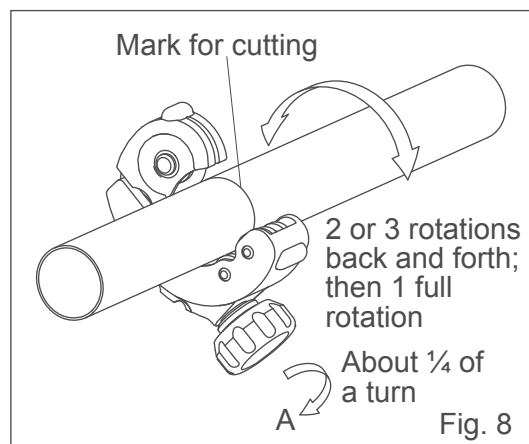
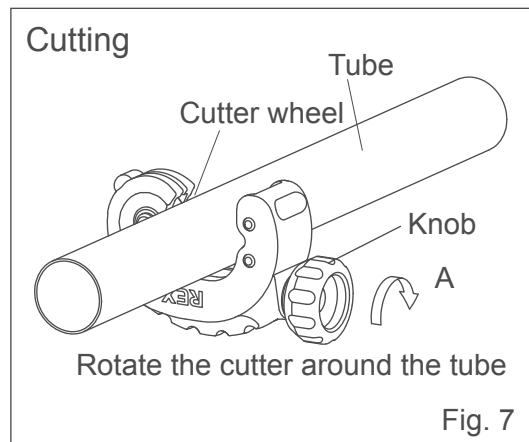
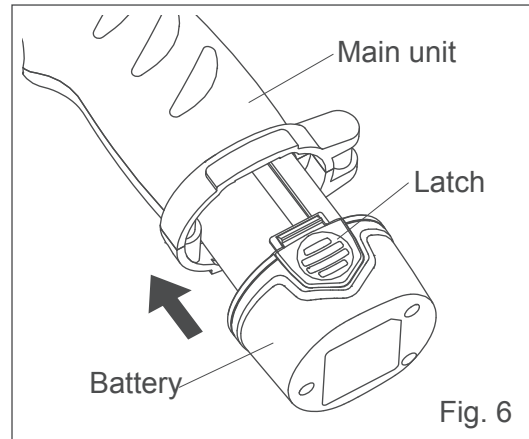

## ⚠ CAUTION

- If you feed the blade too quickly, the tube may be deformed and the tube cannot be flared properly. (Fig. 10 right)

4. Use a scraper, reamer or file etc. to remove burrs from the end of the tube. (Fig. 11)

## ⚠ CAUTION

- Hold the cut end facing downward so that metal chips do not fall into the tube.
- If the cut end has not been properly scraped, the tube cannot be flared properly, and a gas leak may result.
- Do not make any scratches on the inner surface of the tube to be flared. Damage or scratches may remain even after the tube is flared.

## (2) Clamping the tube

1. Slide a flare nut that is compatible with the tube size over the tube. (Fig. 12)

## ⚠ CAUTION

- Before processing, check that the end of the copper tube is not deformed. If it is deformed, you will not be able to process the flare normally.
- Before processing, confirm that there are no burrs left on or in the copper tube. If any burrs remain, the surfaces that are flared may become dented and cause a gas leak.
- Pay attention to the direction of the flare nut.

2. Choose a clamp that is compatible with the tube size, and then place the tube so that the end of it makes contact with the stopper plate. (Fig. 13)

## ⚠ CAUTION

- If there is a space between the tube and the stopper plate, the resulting flare diameter will be smaller.
- Remove any metal chips from the liner, the flare cone and the tube.

\*To open or close the clamp, turn the knob as indicated by the arrow. (Fig. 13)

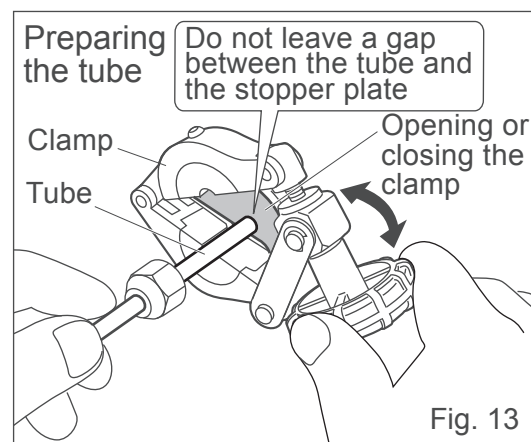
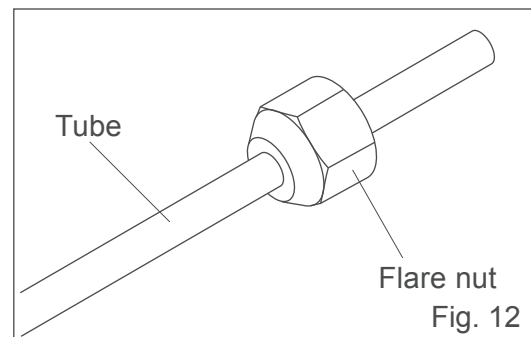
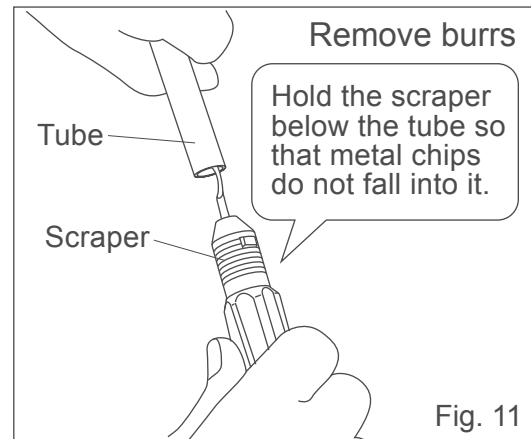
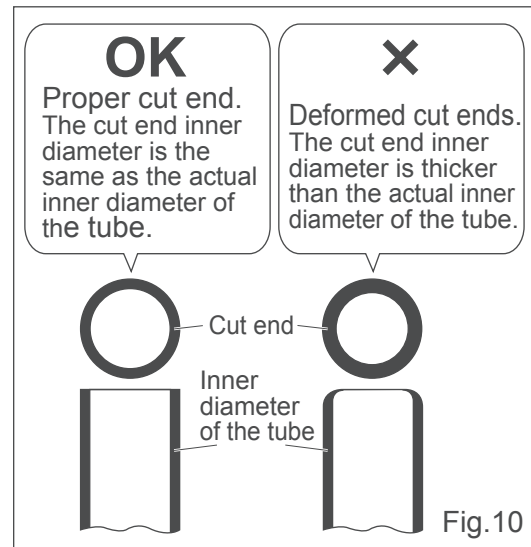

# Operation Guide (Flaring copper tube)

3. Check that the tube is placed correctly and then clamp it. (Figs. 13-14)

**CAUTION**

- To confirm that the stopper plate is in perfect contact with the tube, try to raise the stopper plate slightly with your finger. If the stopper plate is easy to shift, it implies that there is a space between the stopper plate and the tube, so reset the tube. (Fig. 14)

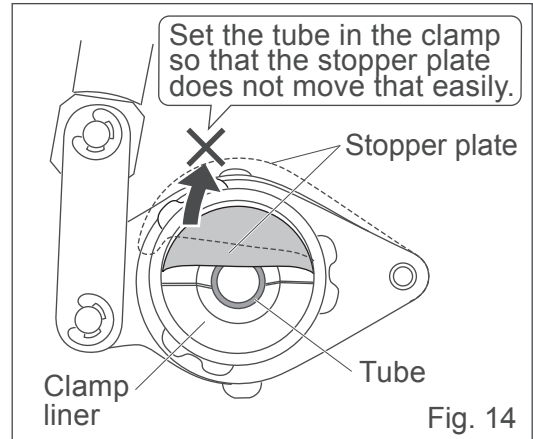

\*Turn the clamp knob until the clamps are closed firmly. (Fig. 15)

Be careful to avoid gaps in the liner as they will cause protrusions in the flare, which will result in leakages. (Fig. 16)

\*The distance between the liners is set slightly smaller than the external diameter of the tube so that the tube will not become loose or slip. Therefore, when clamping the tube, the exterior of the tube will be scratched, but this will not pose any problem.

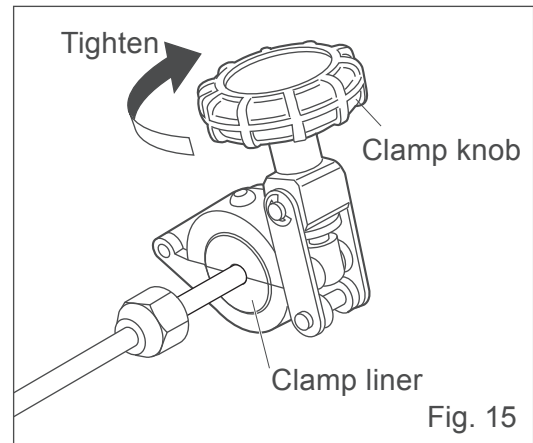

4. When the liner is replaced to change sizes, be sure to fit the new liner properly in the clamp before securing it with the socket bolt. (Fig. 17)

\*Secure the clamp against the liner using the 2.5 mm hex spanner provided and a hex socket button head screw (M4x8).

**CAUTION**

- If there is a large step in setting the liner then there will also be a large step in the flare which will cause a gas leak. (Fig. 18)

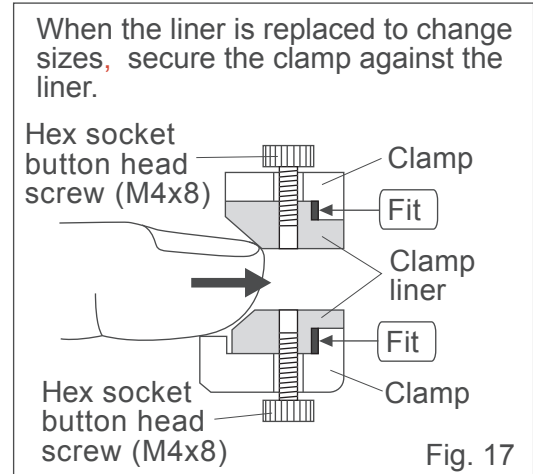
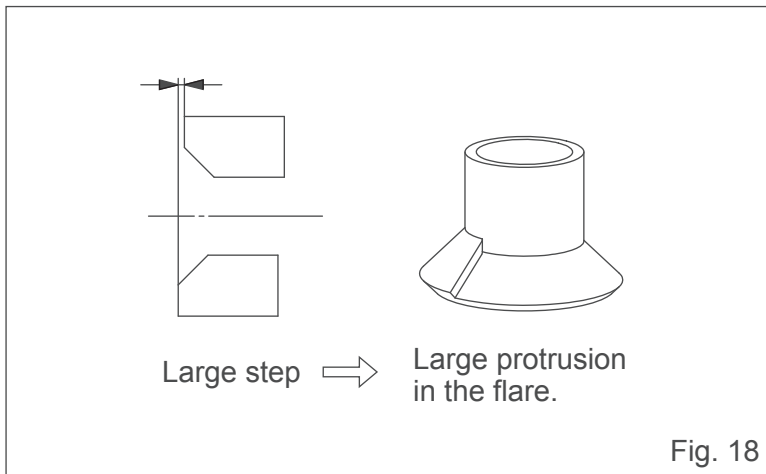
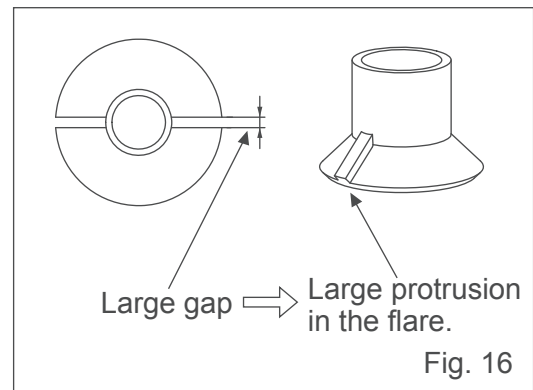



## (3) Flaring

1. Attach the clamp, with the tube in it, to the flaring tool. (Figs. 19-20)

\*Attach the clamp to the flaring tool by aligning the joints on the clamp with the recesses in the flaring tool, and then turn the flaring tool in the direction of the arrow until you hear a click. (Fig. 20)

### ⚠ CAUTION

- You cannot set the clamp unless the flare cone is fully retracted.
- When the cone is out, press REV on the FWD/REV switch and then pull the trigger. The flare cone will retract while rotating in reverse. When the flare cone is fully retracted, you will hear a clank; release the trigger. (Fig. 20)
- Remove any foreign matter (metal chips, etc.) from the flare cone, as these could cause scratches on the inner surface of the flare or a gas leak.

2. Start flaring by pressing FWD on the FWD/REV switch and pull the trigger.

The amount you pull the trigger affects the rotation speed, but you should pull the trigger back all the way.

If you don't pull the trigger back enough, there may not be enough torque.

Flaring should be completed within 3 seconds from when you hear the clutch make a clanking sound.

Release the trigger to stop the tool rotating. (Fig. 21)

### ⚠ CAUTION

- If the time for idling (from when the clutch starts operating until you release the trigger) is too short, it may sometimes result in insufficient flaring.
- If the time for idling is too long, it may cause a gas leak resulting from a protrusion or steps in the flare's exterior (refer to page 13.), or reduce the thickness of the flared tube.

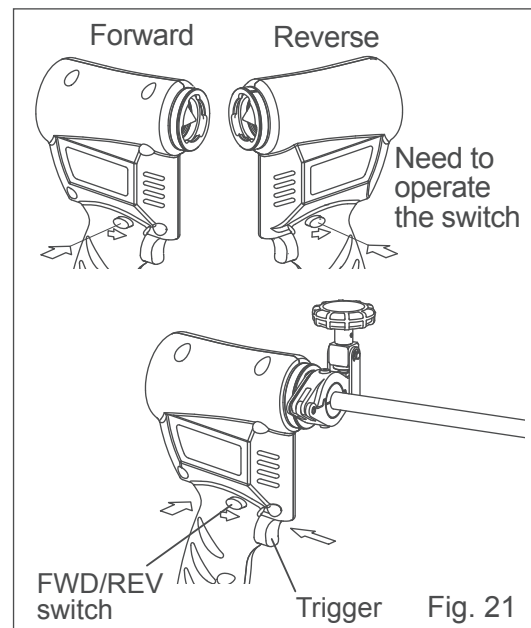
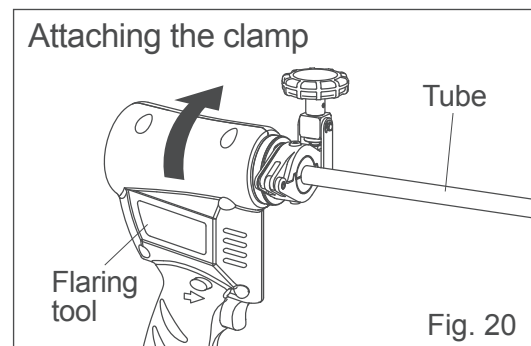
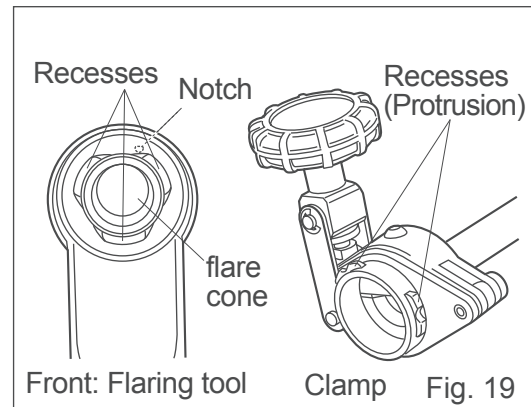

# Operation Guide (Flaring copper tube)

- Press and hold down REV on the FWD/REV switch.
  - The flare cone will be retracted while rotating in reverse. The amount you pull the trigger affects the rotation speed, but you should pull the trigger back all the way.
  - If you don't pull the trigger back enough, there may not be enough torque.
  - When you hear the clutch make a clanking sound, release the trigger to stop the flaring tool rotating.

**⚠ CAUTION**

- If you use the tool when the battery is low, it may stop during processing or retracting. If you feel that the power is getting weaker, charge the battery as soon as possible.

## (4) Removing the tube

- Detach the clamp from the flaring tool by reversing the steps for installation. (Fig. 22)

**⚠ CAUTION**

- The clamp cannot be removed unless the flare cone is fully retracted. Avoid removing it forcibly, otherwise the tool may be damaged.

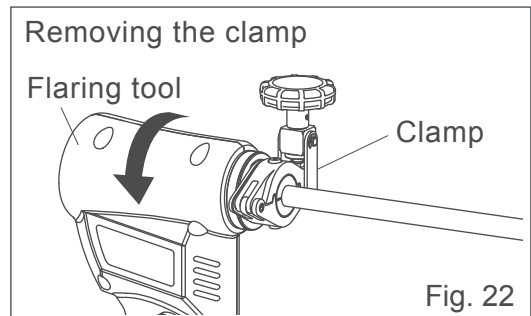

- Removing the tube
  - Loosen the knob to open the clamp, and then remove the tube. (Fig. 23)
  - \*Check the shape and dimensions of the finished flare are acceptable. (Fig. 24).
  - For information on how to deal with each of these cases, refer to Troubleshooting. (Pg. 21)
  - \*Check that there are no foreign bodies such as chips or oil on the processed pipe. If there are, remove with a clean, dry cloth.

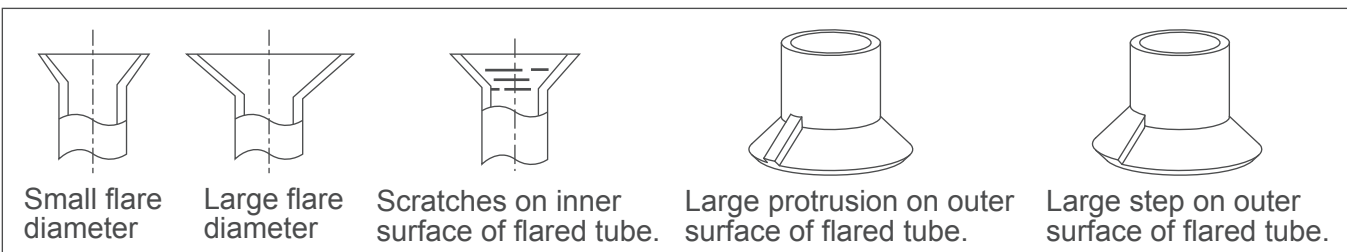
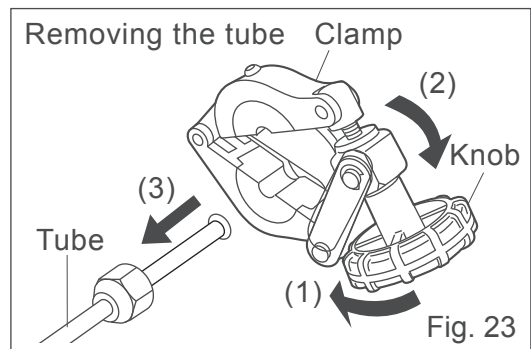

Fig. 24

Points to note when connecting flare nuts on refrigerant tubes  
 - Note the following when connecting flared nuts.

- When connecting a flare nut, coat the thread and taper part of a flare joint with refrigerating machine oil and make the first 3 or 4 turns of the nut by hand.
- Use Table 8 opposite as a guide to the torque that should be applied when connecting a flare nut.
- To prevent gas leaks, ensure the nut is tightened correctly.

**“Tightening torque used for connecting flare nuts (JIS B 8607)”**

Nominal diameter	Actual outer diameter (mm)	Tightening torque (Nm)
1/4"	6.35	14 - 20
3/8"	9.52	40 - 44
1/2"	12.70	57 - 62
5/8"	15.88	70 - 77
3/4"	19.05	98 -120

Table 8

## Operation Guide (Flanging)

### (1) Cutting flexible tubes (Figs. 25, 26)

1. Rotate the grip anticlockwise and retract the cutter blade to fit the flexible tube to be cut.
2. Turn the grip clockwise so that the cutter blade fits into the centre of the recess of the flexible tube, and feed in the cutter.
3. From where it contacts the recess of the flexible tube ridge, turn the grip approx. 1/6 to the right, feed in the blade, and rotate the cutter a few turns in the direction shown in the figure.
4. After that, cut the pipe in the same way (turn the grip to the right about 1/6 turn, then rotate the cutter 2-3 turns).
5. Check that there are no burrs or deformation where the tube has been cut.  
If there are, then normal flanging will not be possible, which could result in leakages. (Fig. 26)

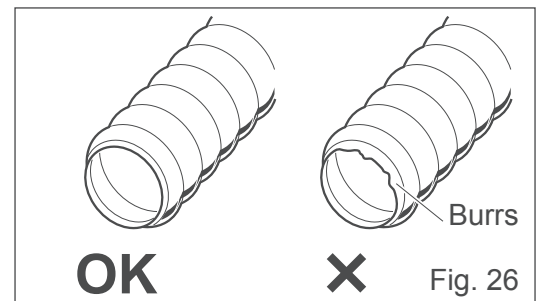
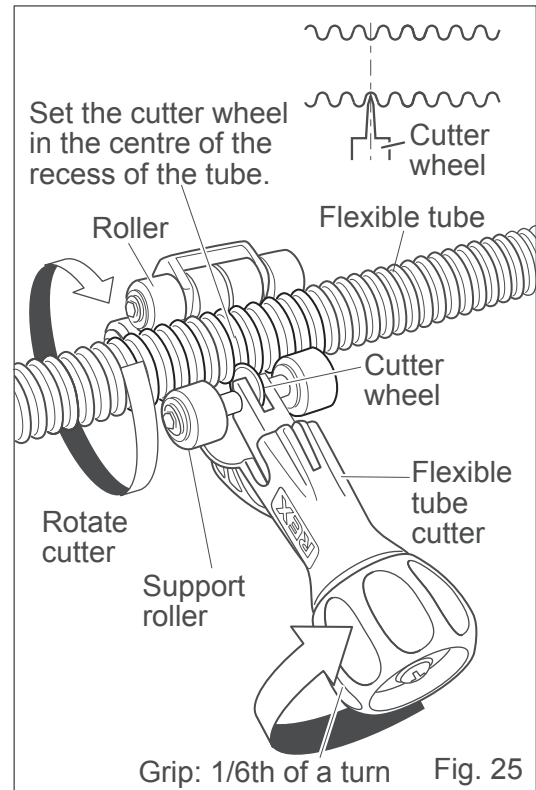

### (2) Setting the clamp (Figs. 27-28)

1. Set the clamp so that you place the liner over the second or third groove from the end of the tube.
2. Lift the handle and tighten by turning in a clockwise direction.
3. While looking from the side, check that the end of the tube does not protrude from the clamp.

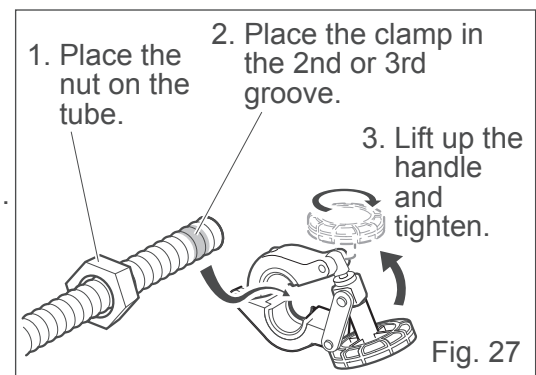

**CAUTION**

- If the end of the tube protrudes beyond the clamp, the clamp cannot be set on the flanging tool.  
If the end of the tube protrudes beyond the clamp, the position of the clamp is incorrect. Correct the position of the clamp.  
If the end of the tube is deformed and protrudes beyond the clamp, cut off the deformed section of the tube and attach the clamp again.

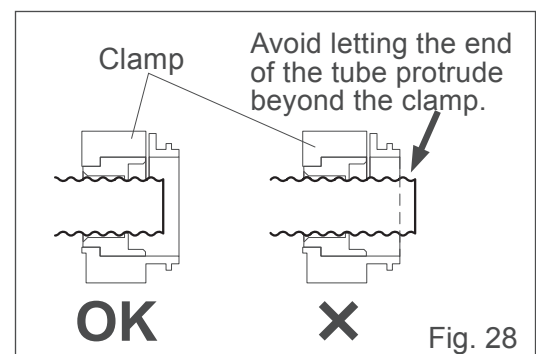

# Operation Guide (Flanging)

## (3) Flanging (Figs. 29-31)

1. Attach the clamp, with the tube in it, to the flanging tool. (Figs. 29-31)

\*Attach the clamp to the flanging tool by aligning the joints on the clamp with the recesses in the flanging tool, and then turn the flanging tool in the direction of the arrow until you hear a click. (Fig. 29)

2. To start flanging, press FWD on the FWD/REV switch and pull the trigger.

The amount you pull the trigger affects the rotation speed, but you should pull the trigger back all the way.

If you don't pull the trigger back enough, there may not be enough torque.

Flanging should be completed within 3 seconds from when you hear the clutch make a clanking sound.

Release the trigger to stop the tool rotating. (Fig. 30)

3. Press and hold down REV on the FWD/REV switch and pull the trigger.

The flanging cone will retract while rotating in reverse.

As in 2 above, the amount you pull the trigger can affect the rotation speed, but you should pull the trigger back all the way.

If you don't pull it back enough, there may not be enough torque.

Release the switch to stop the tool rotating.

4. Remove the clamp in the reverse order to attaching it.

5. Make sure the tube has been flanged correctly.

\*If it hasn't, it can lead to water leaks or electrolytic corrosion. (Fig.31)

\*Make sure that the processed tube is free of foreign bodies such as chips and/or oil.

If there are any, remove with a clean, dry cloth.

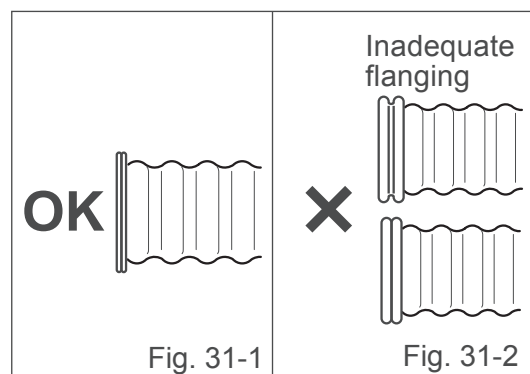
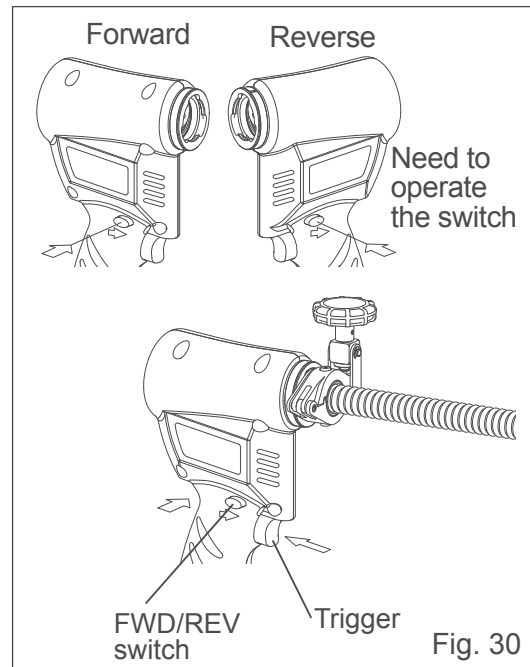
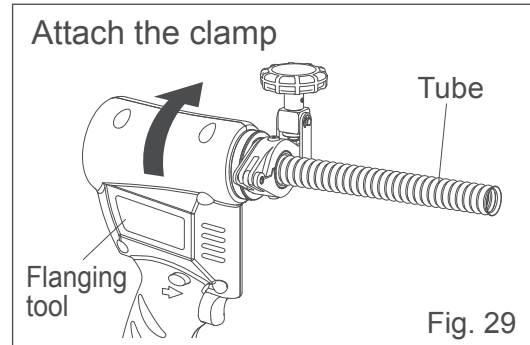

## (Replacing the flaring or flanging cone) **Operation Guide**

The RF20S flaring tool can be used to flare flexible tube by attaching special (optional) accessories.  
The RT20S flanging tool can also be used to flare copper tube by attaching special (optional) accessories.

Special accessories (For details, refer to pages 22-23.)

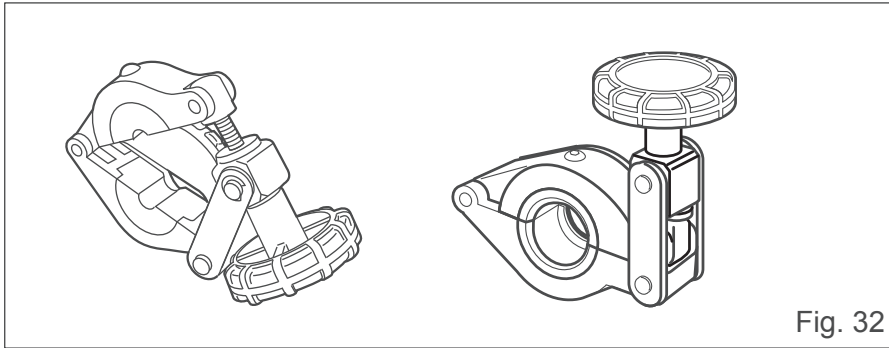

1. Clamps (for RF20S / for RT20S)

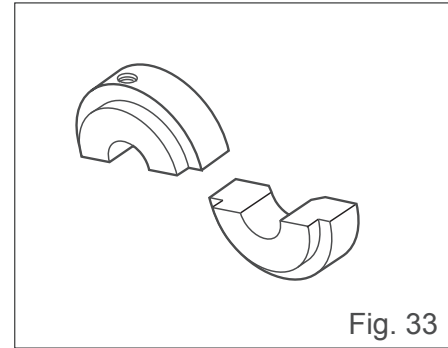

2. Liners

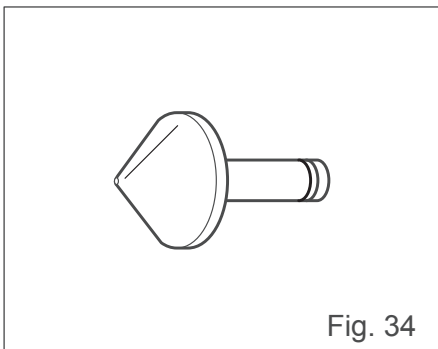

3. Flaring cone

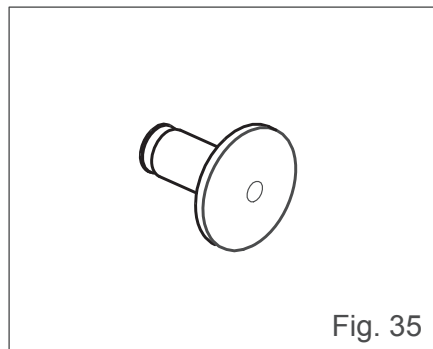

4. Flanging cone

### Replacing the flaring or flanging cone (Fig. 36)

1. Press the FWD / REV switch forward, pull the trigger, and move the flaring or flanging cone forward as far as it will go.
2. Remove the battery.
3. Insert a flat-head screwdriver between the cone and the body of the tool and take out the cone while taking care not to lose the thrust bearing.
4. Insert the cone until you hear it click into place.
5. Replace the battery.

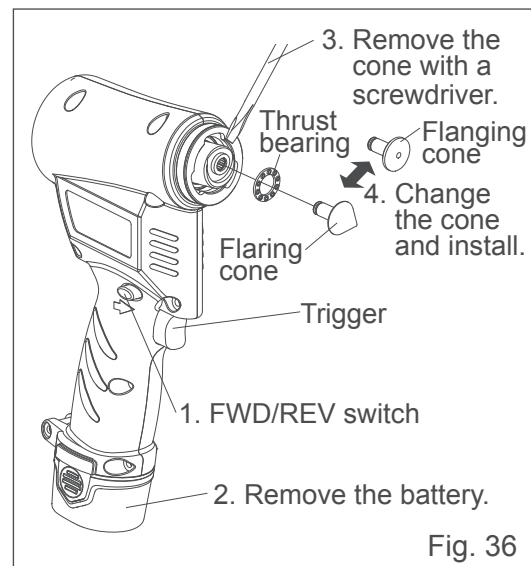

Fig. 36

### **WARNING**

- When replacing the cone, remove the battery from the tool, otherwise there could be an accident if the tool starts up suddenly.

# Maintenance and Care

## ⚠ CAUTION

- Before inspection or maintenance, be sure to turn OFF the switch and also remove the battery. If the battery is not removed, it may start unexpectedly, causing serious injury.
- When an abnormality is found during inspection or maintenance, identify the problem referring to the descriptions in "Before Asking for Repairs or Servicing" and then follow the relevant instructions. Using the product as is, without correcting the abnormality, may generate excessive heat, fumes, or fire, causing serious accidents or injury.

### 1. Check all screws

- Check all screws on a regular basis and tighten any that are loose. Using the tool if any screws are loose can be dangerous.

### 2. Keep surfaces clean

- Clean the outside of the charger with a soft, dry cloth or with a cloth dampened in soapy water. Do not use chlorine-based solvents, gasoline or paint thinner as they may dissolve the plastic. Also, when using the tool, oil may ooze out from a gap in the main body or cone. This is due to the separation of liquid oil from the grease used inside the main unit, and there is no functional problem. It is not a malfunction; just wipe with a dry, clean cloth.

### 3. Store properly after use

- After the job is finished, store in a dry place where the temperature does not exceed 40°C and with the battery separated from the charger. Keep out of the reach of children.

### 4. Care of the clamp

- If the knob is stiff when you tighten it, apply oil, grease, etc. as shown in the figure on the right. (Fig. 37)

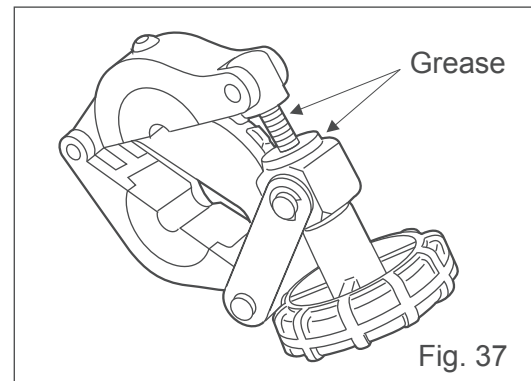

## Servicing and Repairs

This product is produced with great precision; therefore, should it fail to operate normally, do not disassemble or repair it by yourself; contact your distributor or REX INDUSTRIES CO., LTD.

If you do not find any problem or remedy in Troubleshooting in this manual, or parts are required or if you have any questions, please contact us at your earliest convenience.

### Availability of Replacement Parts

Replacement parts are maintained for a period of 7 years after production of this model has been terminated.

Electrical parts, however, will remain available for a period of 5 years.

# Before Asking for Repairs or Servicing

If an abnormality occurs with the product, check the following and then contact your distributor or REX INDUSTRIES CO., LTD.

## ⚠ CAUTION

- If there is no description of, or instructions regarding, the problem in question in the following table, never try to disassemble or repair the product by yourself.
- If any problems are not dealt with below or if there are any instructions that indicate repair or servicing are needed, be sure to contact the manufacturer or the distributor from whom you purchased the product.
- If the product is repaired by personnel without the proper knowledge or skills, it may cause serious accidents or injury, as well as adversely affecting the performance.

## Troubleshooting (RF20S)

Problem	Cause	Remedy
The diameter of the flare is too small.	The tube end was pinched due to feeding the blade too quickly when the tube was cut.	Feed the cutter blade more slowly to cut the tube. (Refer to page 12.)
	Burrs were left on the tube end.	Remove the burrs. (Refer to page 13.)
	There was a space between the tube end and the stopper plate.	Place the tube, taking care not to leave a space between the tube end and the stopper plate. (Refer to page 13.)
	The idling time from when the clutch started operating was too short.	Increase the idling time. (Refer to page 15.)
	Flaring pressure is diminished.	Ask for inspection or repairs. (Refer to page 20.)
The diameter of the flare is too large.	Tube end is protruding from the stopper plate.	Place the tube so that the tube end is in contact with the stopper plate. (Refer to page 13.)
	The idling time from when the clutch started operating was excessive.	Decrease the idling time. (Refer to page 15.)
Ring-shaped flaws occur on the inside of the flare. (If the flaws are superficial, this does not pose a problem.)	Large burrs were left on the tube end.	Remove the burrs. (Refer to page 13.)
	The idling time from when the clutch started operating was too short.	Make the idling time longer. (Refer to page 15.)
	Flaring pressure is diminished.	Ask for inspection or repairs. (Refer to page 20.)
Flaws other than ring-shaped ones (vertical flaws, dents, etc.) occur on the flared inner surface of the tube.	Flaws were made while removing burrs inside the tube.	Remove the burrs without making any flaws on the inside of the tube. (Refer to page 13.)
	Dirt or scrap adhered to the flare cone or the inside of the tube.	Remove any dirt or scrap. (Refer to page 13.)
	Flaring pressure is diminished.	Ask for inspection or repairs. (Refer to page 20.)
A larger protrusion (0.3 mm or more) can be seen on the external surface of the flare.	The clamp knob wasn't tightened enough leaving too much clearance between the liners.	Tighten the clamp knob until there is no space between the liners.
A larger step (0.3 mm or more) can be seen on the external surface of the flare.	The liner was attached with steps in it.	Attach the liner without steps. (Refer to page 14.)
	There was a step (0.3 mm or more) on the surface of the clamp where the liner was installed.	Ask for inspection or repairs. (Refer to page 20.)
The flare is not symmetrical.	Flaring was done on a tube that was cut at an angle.	Cut at right angles to the tube.
	Flaring was done on a tube that was too flat or bent.	Flare the tube where it is not too flat or bent.

Table 9

# Before Asking for Repairs or Servicing

## Troubleshooting (RT20S)

Problem	Cause	Remedy
Unsatisfactory shape of the flange.	The idling time from when the clutch started operating was too short.	Increase the idling time. (Refer to page 18.)
You cannot attach the clamp with the tube in it to the flanging tool.	The end of the tube is protruding beyond the clamp. (The number of threads is wrong or the tube is too deformed.)	Check the number of threads and see if the tube is deformed. (Refer to page 17.)
You can hear the sound of the motor but the flanging tool won't flange even when the trigger is pulled back.	The end of the tube is protruding beyond the clamp. (The number of threads is wrong or the tube is too deformed.)	Check the number of threads and see if the tube is deformed. (Refer to page 17.)
	The internal mechanism of the flanging tool is damaged.	Ask for inspection or repairs. (Refer to page 20.)

Table 10

## Troubleshooting (RF20S / RT20S)

Problem	Cause	Remedy
The flaring/flanging tool does not work even when the trigger is pulled back.	The battery has run out.	Recharge the battery. (Refer to page 11.)
	There are insulators, such as dirt, between the battery and the contacts on the tool.	Remove the insulators.
	The wiring or the motor is faulty.	Ask for inspection or repairs. (Refer to page 20.)
Oil oozes from a gap in the tool or cone.	Liquid oil has separated from the grease and oozes out.	This is not a malfunction. There is no functional problem, so wipe with a clean, dry cloth.

Table 11

## Troubleshooting (Charger RF20SC)

Problem	Cause	Remedy
The green lamp does not flash on and off slowly, even if connected to the power. (Battery has not been set up properly)	The power cord is broken.	Replace the power cord.
	Fault with the power supply (breaker etc.).	Check the power supply.
	The charger is out of order.	Ask for inspection or repairs. (Refer to page 20.)
The red lamp on the charger is flashing slowly.	The temperature of the battery is outside the proper range.	Ensure that you operate within the chargeable temperature range for the battery. (0 - 40°C)
The red lamp on the charger does not light up. (Charging is not possible.)	There are insulators, such as dirt, between the battery and the contacts on the tool.	Remove the insulators.
The red and green lamps on the charger are lit at the same time.	The battery is out of order.	Replace the battery.
The green lamp does not light up even if you charge it for more than two hours. (Charging is not completed)	The charger is out of order.	Ask for inspection or repairs. (Refer to page 20.)

Table 12



# Optional Accessories for RF20S

\*Optional accessories are also sold separately as below.

## 1) Clamp for flaring (Fig. 38)

Part No. 424950

Used when flaring copper tube.

Liners and cones for flaring copper tube are required.

Although it is possible to cope with different tube sizes by replacing just the liner with an appropriate one, we recommend you flare  $\frac{1}{4}$ ",  $\frac{3}{8}$ ",  $\frac{1}{2}$ ",  $\frac{5}{8}$ " or  $\frac{3}{4}$ " diameter copper tubes using a clamp with a suitable liner as one set.

## 2) Liners for flaring (Fig. 39)

Part No.	Model
424850	New refrigerant class 2 liner $\frac{1}{4}$ " (6.35 mm)
424852	New refrigerant class 2 liner $\frac{3}{8}$ " (9.52 mm)
424853	New refrigerant class 2 liner $\frac{1}{2}$ " (12.70 mm)
424854	New refrigerant class 2 liner $\frac{5}{8}$ " (15.88 mm)
424855	New refrigerant class 2 liner $\frac{3}{4}$ " (19.05 mm)

These liners are used for  $\frac{1}{4}$ ",  $\frac{3}{8}$ ",  $\frac{1}{2}$ ",  $\frac{5}{8}$ " and  $\frac{3}{4}$ " copper tubes, respectively.

Purchasing a liner together with a clamp as a set saves labour when replacing liners.

## 3) Batteries (Lithium-ion batteries) (Fig. 40)

Part No. 424982

For convenience, keep a spare battery.

No other manufacturer's battery can be used.

## 4) Charger (Fig. 41)

Part No. 424985 / 424961 / 424981

No other manufacturer's charger can be used.

## 5) Carrying case (Fig. 42)

Part No. 424959

## 6) Flanging tool set (Fig. 43)

Part No. 424980

\*By using the tool sets, the RF20S can be used as a flanging tool. These sets are used for flanging stainless flexible tubes for water supply, respectively.

Contents:

Flanging cone	1
Clamp for flanging	2
Flanging liner for $\frac{1}{2}$ "	1 Set
Flanging liner for $\frac{3}{4}$ "	1 Set
Hex key	1

## 7) RB tube cutter Model N28 (Fig. 44)

Part No. 427128

### 1) Clamp

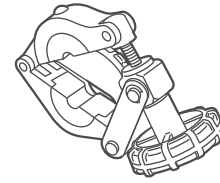

Fig. 38

### 2) Liners

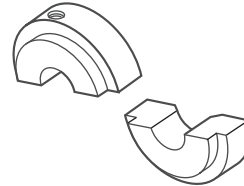

Fig. 39

### 3) Batteries (Lithium-ion batteries)

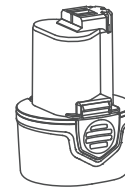

Fig. 40

### 4) Charger

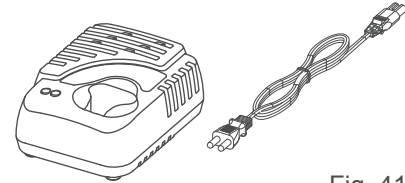

Fig. 41

### 5) Carrying case

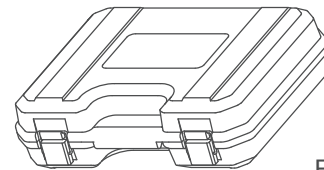

Fig. 42

### 6) Flanging tool set

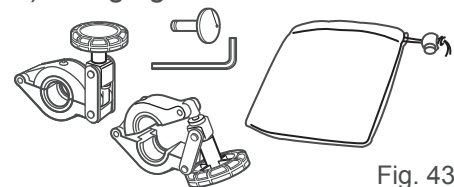

Fig. 43

### 7) RB tube cutter Model N28

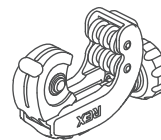

Fig. 44

# Optional Accessories for RT20S

\*Optional accessories are also sold separately as below.

## 1) Clamp for flanging (Fig. 45)

Part No. 424975

Used when flanging stainless flexible tube.

Liners and cones for flanging stainless flexible tube are required.

## 1) Clamp

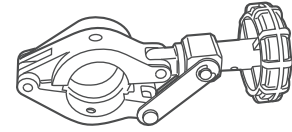

Fig. 45

\*When flaring copper tube with the RT20S, separate clamps, liners and cones for flaring copper tube are required. (Refer to Figs. 38-39, Fig.50)

Although it is possible to cope with different tube sizes by replacing just the liner with an appropriate one, we recommend you flange 1/2", and 3/4" diameter stainless flexible tubes using a clamp with a suitable liner as one set.

## 2) Liners

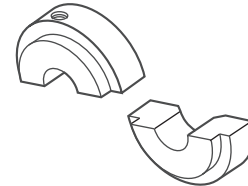

Fig. 46

## 2) Liners for flanging (Fig. 46)

Part No.	Model
424777	Flanging liner 1/2" (16.8 mm)
424778	Flanging liner 3/4" (20 mm)

These liners are used for 1/2" and 3/4" stainless flexible tubes, respectively.

Purchasing a liner together with a clamp as a set saves labour when replacing liners.

## 3) Batteries (Lithium-ion batteries)

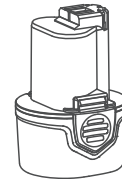

Fig. 47

## 3) Batteries (Lithium-ion batteries) (Fig. 47)

Part No. 424982

For convenience, keep a spare battery.

No other manufacturer's battery can be used.

## 4) Charger

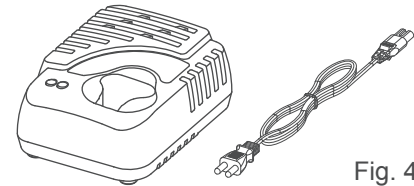

Fig. 48

## 4) Charger (Fig. 48)

Part No. 424985 (220-230V)

424961 (100-120V)

424981 (220V special)

No other manufacturer's charger can be used.

## 5) Carrying case

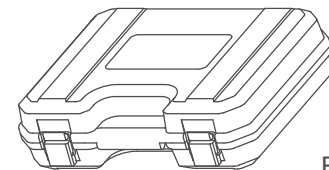

Fig. 49

## 5) Carrying case (Fig. 49)

Part No. 424984

## 6) Flare cone (Fig. 50)

Part No. DF14

Flare cone used for flaring copper tube.

Refer to Pg. 16 for replacing flare cones.

## 6) Flare cone



Fig. 50

## 7) Flexible tube cutter (Fig. 51)

Part No.	Model	Code / Cutter wheel
1703F2*	Flexible tube cutter 20	424200
1713F3	Flexible tube cutter 25N	Cutter wheel for Flexible tube cutter 20
1713F5	Flexible tube cutter Click 25N	
1703F3*	Flexible tube cutter 25	1703F7
1703F4*	Flexible tube cutter 32	Cutter wheel for Flexible tube cutter 20 / 32
1713F4	Flexible tube cutter Mini 32N	

\*Old model

## 7) Flexible tube cutter 20

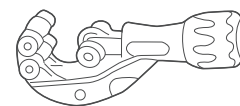

Fig. 51



## ⚠ Guarantee and Exemption from Liability

1. Should the product happen to break down for no apparent reason, despite normal and correct use, repairs and service parts shall be provided free of charge as outlined below.

Repairs shall be provided free of charge for a period of one year from date of purchase.

Dates, procedures and methods for providing repairs and service parts shall be decided in consultation with the customer.

After the one-year guarantee period, all repairs and service parts will be charged.

Repairs may be charged even within the guarantee period under the following circumstances:

- if the product has not been used according to the instructions in the Operation Manual
- if it has been used for anything other than its intended purpose
- if it has not been repaired according to the Operation Manual or if it has been remodeled
- if consumables need replacing
- if it has been handled in an inappropriate way.

2. REX will accept no responsibility under the following circumstances:

- if a malfunction or accident occurs as a result of fire, abnormal fluctuations in voltage, damage from flood, earthquakes, lightning or other natural disasters, war, conflict, riot, terrorism or pollution, etc.
- when the product has not been operated according to the Operation Manual
- when the product has been used incorrectly, repaired or remodelled inappropriately
- when a malfunction or accident results from using a workpiece made on the product, or leaving it lying around and/or if it is exposed to the elements
- when a malfunction or accident results from using a workpiece produced on the product either while or after connecting it.

3. Any costs incurred by the manufacturer shall not exceed the purchase price of the product.



The terminals on used lithium-ion batteries should be wrapped in insulating tape to prevent short circuits, and should be disposed of in accordance with the relevant, prevailing laws of the country of use.

## ⚠ Environmental Protection

Observe national regulations on environmentally compatible disposal and on the recycling of disused machines, packaging and accessories.

Battery packs must not be disposed of with regular waste. Return faulty or used battery packs to your Rex distributor!

Do not allow battery packs to come into contact with water!

 For EU countries only: Never dispose of power tools in your household waste!

In accordance with European Guideline 2002/96/EC on used electronic and electric equipment and its implementation in national legal systems, used power tools must be collected separately and handed in for environmentally compatible recycling. Before disposal, discharge the battery pack in the power tool.

Prevent the contacts from short circuiting (e.g. by protecting them with adhesive tape).

# REX

## REX INDUSTRIES CO., LTD.

Overseas Sales Dept. & Factory :

1-9-3, Hishiya-Higashi, Higashi-Osaka 578-0948 Japan

Tel.: +81 - (0)72 - 961 - 9820 Fax.: +81 - (0)72 - 961 - 9878

URL <http://www.rexind.co.jp>

6V51-E2

RF/RT20S

2010D 0300