



Be sure to read this Operation Manual thoroughly before use, to operate properly.
Be sure to keep the manual where the operator can refer to it whenever necessary.

Names of parts

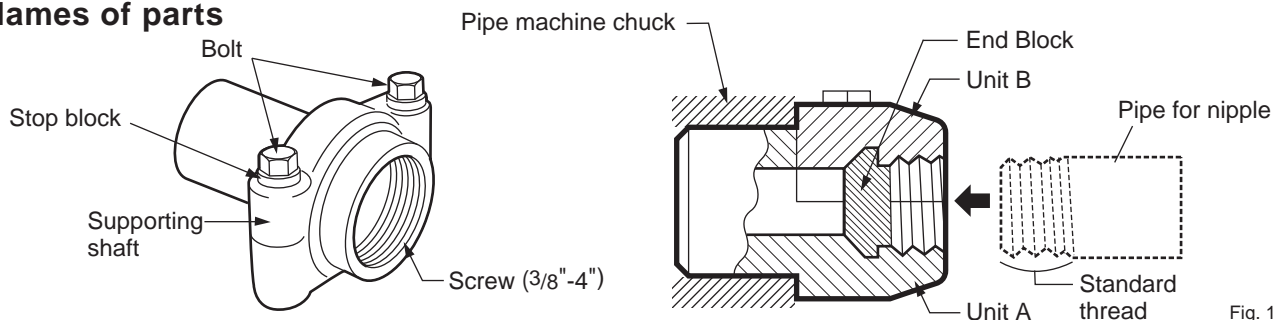
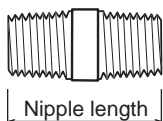

Fig. 1



Minimum nipple length

Attachment size	NPT BSPT	3/8"	1/2"	3/4"	1"	1 1/4"	1 1/2"	2"	2 1/2"	3"	4"
Minimum nipple length (inch)		2.2"	1.8"	2.0"	2.2"	2.6"	2.6"	2.75"	3.0"	3.2"	3.9"
Minimum nipple length (mm)		55	45	50	55	65	65	70	75	80	100

Table 1

Instructions

1. Insert the attachment into the chuck of the pipe machine with the two bolts facing upwards.
2. Tighten the bolts with a T-wrench to ensure there is no gap between units A and B. (Fig. 2)
3. Screw in a properly threaded pipe until it reaches the End block. (Fig. 3)
Use the pipe that is longer than the minimum length shown in Table 1 above.
4. Cut a thread in the usual way.
5. After threading the pipe, stop the machine, loosen the chuck and adjust the position of the two bolts so that they are facing upwards. (This can also be done switching machine on and off.)
6. Turn both bolts two or three times to loosen the attachment. Unthread the completed nipple by hand and remove it. (Fig. 4)
7. Once you've finished, loosen the chuck, remove the attachment and store it in a safe place.

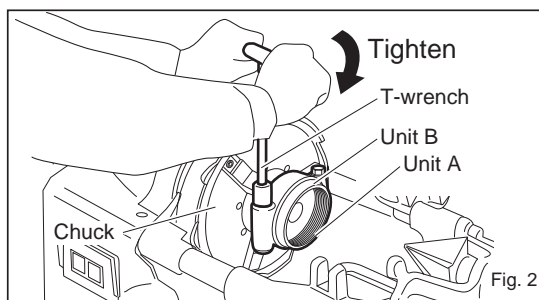

Fig. 2

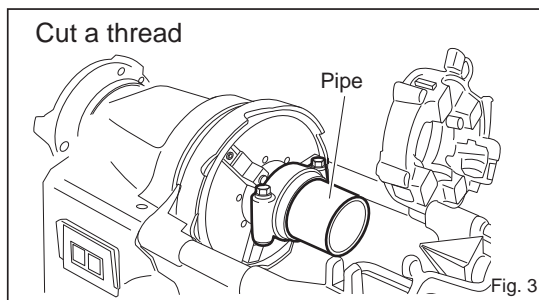

Fig. 3

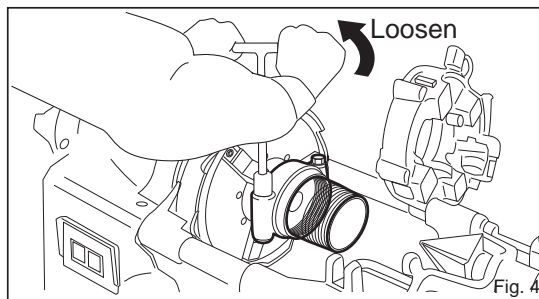

Fig. 4

CAUTION

- Moving parts can be dangerous. Always make sure the machine is switched off and has come to rest before handling the attachment.
- When making short nipples, make sure the attachment avoids hitting the die head.
- When chucking the attachment, use your right hand to support the attachment while making sure you keep it centred.
- The thread you cut should be a standard thread.
- When joining to a coupling, decide on the most appropriate way for checking the processed thread, washing it, selecting and applying the sealant, applying torque when tightening the thread, etc.
- If the bolts are not tight enough, there may be a gap, resulting in a defective thread.

REX INDUSTRIES CO., LTD.

Overseas Sales Dept. & Factory :
1-9-3, Hishiya-higashi, Higashi-Osaka 578-0948, Japan
Tel.: +81-(0)72-961-9820 Fax.: +81-(0)72-961-9878

URL <http://www.rexind.co.jp>