

50/60Hz

REX

LIGHT GROOVE 150DX

RG150/RG150A

OPERATION MANUAL

ORIGINAL INSTRUCTION

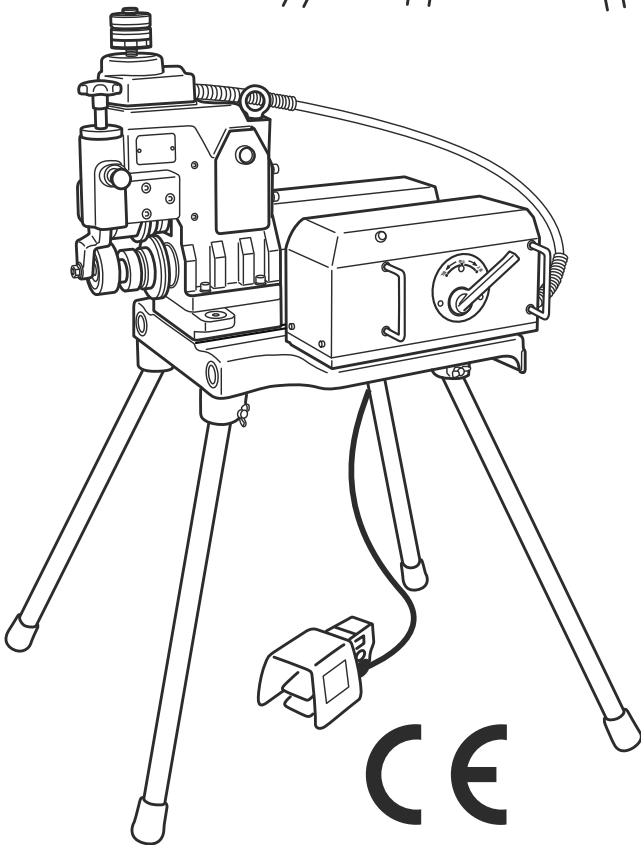
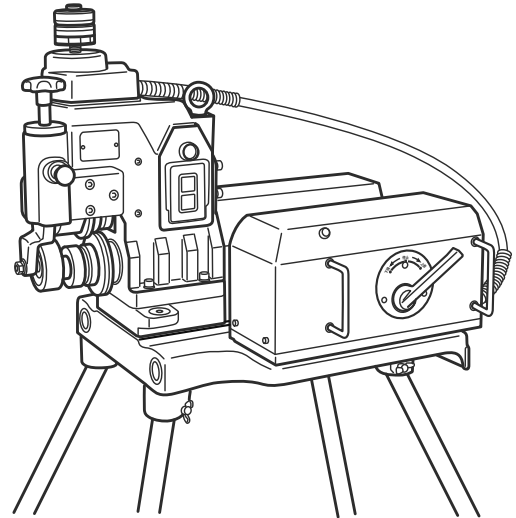
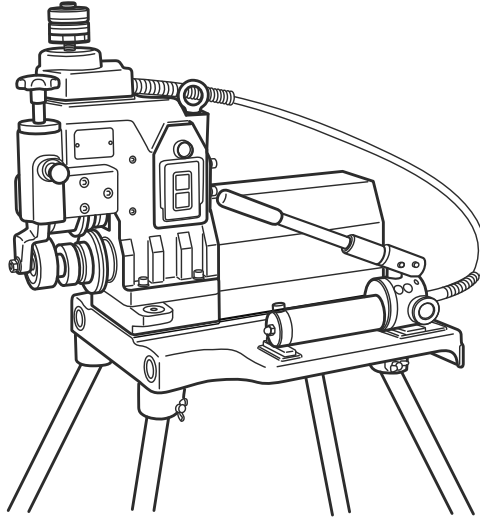

CE



**Be sure to read
this operation manual
before using the machine.**

- Note -

- Be sure to hand this operation manual to the user.
- To ensure safe and efficient use, read the manual thoroughly before using the machine.
- Be sure to keep the manual where the operator can refer to it whenever necessary.

Date of Purchase: Year Month

Distributor:

Thank you for purchasing a REX Roll Grooving Machine.

Our product will give you years of reliable service if you simply follow the instructions in this manual carefully.



- To prevent accidents such as fire, electric shock, injury etc., please be sure to observe the Safety Considerations and Precautions when using the Light Groove
- Before using the product, therefore, make sure you read the manual from start to finish, paying particular attention to the Safety Considerations and Precautions.
- To avoid accident and injury, never use the machine for any purposes other than those described in this manual.

Should you need further advice, contact your distributor or REX Industries Co., Ltd.

CONTENTS

1. Safety Considerations	1
2. Precautions when using the Light Groove 150DX	3
3. Main Parts, Standard Specifications, Accessories, Options, Application	4
4. Getting Ready	
1. Setting Up	5
2. Setting Up the Pipe	6
3. Operating the Pump	8
5. Operation Guide	
1. Adjusting Groove Depth	9
2. Grooving	10
3. Confirm groove dimensions	11
4. Pipe Chamfer	13
5. Carrying the machine	13
6. Servicing and Repairs, Troubleshooting	14
7. Daily Inspection, Maintenance	15
8. Requesting Repairs	16
9. Explanation of Symbols	16

Definitions of WARNING and CAUTION

In this operation manual, warnings are divided into  WARNING and  CAUTION

 **WARNING** : indicates actions that could possibly result in death or severe injury to the user if the machine is used incorrectly.

 **CAUTION** : indicates actions that could possibly result in injury to the user, or physical damage, if the machine is used incorrectly.

- Even items marked  CAUTION could have serious outcomes under certain conditions. Be sure to observe these warnings carefully as they greatly affect safety.

-
- If this manual is lost or damaged, promptly order a replacement from your distributor or our sales department. Also you can download this manual from REX's website (www.rexind.co.jp).
 - Parts and specifications are subject to change without prior notice, due to improvements in quality, performance or safety standards. In such cases, the contents, photographs, illustrations, etc. in this manual may be different to the product you have purchased.

1. SAFETY CONSIDERATIONS

WARNING

1. Ensure you use the correct voltage.

- Be sure to use the voltage indicated on the nameplate on the main unit or in this manual. If the voltage is different from the voltage indicated, overheating, smoke or fire may occur.

2. Check the switch is OFF before inserting the plug into the power supply socket.

- If the plug is inserted into the power supply when the switch is ON, the machine may start operating abruptly and is liable to cause accidents. Be sure to check the switch is OFF.

3. Avoid electric shock.

- Never touch the plug with wet hands.
- Do not use the machine in rain or in places where moisture can easily get into the machine.
- Be sure to ground the machine to avoid electric shock.

4. Be aware of the environment you are working in.

- Do not use the machine in the rain, in humid or damp places, or places where moisture can easily get into the machine. Humidity will lower insulation of the motor and cause electric shock.
- Do not use close to flammable fluids or gases, such as gasoline and thinner. Doing so might result in fire or explosion.

5. Use designated accessories and attachments.

- Do not use accessories and attachments other than those designated in this manual or our catalogues. Accident or injury might result if you do.

6. In the following cases, turn the unit OFF and pull the plug out of the socket:

- when the machine is not in use or parts are changed, repaired, cleaned or inspected,
- when accessories are changed,
- when hazards are expected (including a power failure),
- when the plug is inserted (the machine may start up unexpectedly, which could cause an accident).

7. If any abnormality is noticed, stop the machine immediately.

- If the machine does not operate smoothly, or abnormalities such as unusual odors, vibration or noise are detected, stop operating the machine immediately.
- Check symptoms against the items listed under "Troubleshooting" at the end of this manual and follow the corresponding instructions. Continuing to use the machine may result in overheating, smoke or fire, and may cause accident or injury.
- If the unit overheats or produces smoke, do not attempt to overhaul it yourself but ask for an inspection and repair.

8. Keep the work site clean.

- Ensure you keep workbenches and the worksite in good order and well lit. Cluttered worksites and workbenches are liable to cause accidents.

9. Do not let any unauthorised personnel near the machine.

- Do not let anyone other than authorised personnel touch the machine or the power cord, or operate the machine.
- Do not let anyone other than authorised personnel enter the work site, especially children. They could get seriously injured.

10. Do not apply excessive force.

- To ensure safe and efficient operation, use within the capacity of the main unit. Applying force may not only cause damage to the product but could also result in accident or injury.
- Do not use the machine in any way that could cause the motor to lock, or cause smoke or fire.

11. Use the machine only for its designated purpose.

- Do not use the machine on pipes not specified in this manual. Using the machine for any purpose other than grooving pipes, such as fastening the pipe to a joint etc., will not only damage the machine and/or motor but could also lead to accident or injury.

1. SAFETY CONSIDERATIONS

WARNING

12. Wear proper working clothing.

- Do not wear neck ties, clothes with open sleeves, loose clothing, accessories such as necklaces, etc. Do up buttons and zippers which could get caught in the rotating parts and result in serious accident or injury.
- When working outdoors, it is recommended that you wear rubber gloves and non-slip shoes. Slippery gloves and shoes are liable to cause injuries. Do not wear scarves and cover long hair with caps or hair nets to prevent them getting caught in rotating parts.
- Wear safety caps, safety shoes, etc. according to the working environment.

13. Do not work in an unnatural posture.

- Keep a firm footing and balance to avoid falling over and injuring yourself.

14. Remove tools such as wrenches.

- Before turning the switch ON, check that tools used for inspection and adjustment have been removed. If you use the machine when tools are left inside it, accidents and injuries may occur.

15. Operate the unit with great care.

- Always work with great attention to how you handle and operate the machine and the surrounding conditions. Carelessness may result in accident or injury.
- Do not operate the machine when concentration is lowered such as when tired, after drinking alcohol, when sick, affected by medicine, etc.

16. Do not handle the power cord carelessly.

- Do not carry the machine by the cord, or pull the plug out of the socket with the cord.
- Do not place the cord near heated objects, fats and oils, cutters or objects with sharp edges.
- Take care not to tread on the cord, pull it or apply unnecessary force resulting in damage to the cord. Doing so may result in electric shock or short-circuit may occur, causing fire.

17. Perform careful maintenance daily.

- When changing accessories and parts, follow the operation manual
- Periodically inspect the power supply cord and plug. If damaged, ask your distributor or our sales department for repairs. There is a risk of electric shock or short-circuiting and fire.
- If an extension cord is used, inspect the cord periodically and, if damaged, replace it. If extension cords are used outdoors, use extension cords designed for outdoor use to prevent electric shock, short-circuit or fire.
- Keep parts used for gripping the unit dry and clean, and free of oil and grease. If your hands slip, you may be injured.

18. Check for damaged parts.

- Before using the machine, carefully check for damage to the protective cover and other parts, and check both normal operation and specified functions.
- Check for any abnormalities such as in adjustment of movable parts, tightening, damage to and installation of parts and all parts affecting operation.
- Do not use machines with a damaged power cord or plug. Doing so may cause electric shock or a short circuit leading to fire.
- Do not use machines if the Stop and Start switches do not work properly.
- When replacing or repairing a broken protective cover and other parts, follow the operation manual. If no instructions are specified in the operation manual, ask your distributor or our sales department for repairs.

19. Store carefully when the machine is not in use.

- Store in a dry place away from children and locked with a key.

20. For overhaul and repair of the machine, ask an appointed REX agent.

- Our products comply with corresponding safety standards. Do not remodel.
- Be sure to ask your distributor or our sales department for any repairs. If repairs are carried out by unskilled or unqualified personnel, the performance of the unit will be adversely affected and may result in accident or injury.

2. PRECAUTIONS WHEN USING THE LIGHT GROOVE 150DX

WARNING

1. Use rollers that match the pipe being processed. (Refer to Fig. 1, Fig. 5)

The standard set of rollers can be used only for 50A - 150A (2" - 6") steel pipe (SGP or Schedule 10- 40). They cannot be used for thin wall stainless steel pipes or pipes of a different size. The applicable sizes are marked on the rollers; replace rollers according to the size of pipe.

2. Never touch rotating parts.

To prevent hands and fingers from getting caught, never touch rotating rollers and pipes with your hands.

3. When replacing or inspecting the rollers, turn the switch OFF and pull the cord out of the socket.

To prevent unforeseen accidents, be sure to turn the switch OFF and pull the plug out when replacing or checking the rollers.

4. Insert the pipe correctly. (Refer to Pg. 6, 2. Setting up the pipe.)

Use a spirit level to check the pipe is horizontal. Set up the pipe in the right direction and at about 3° to the machine.

Note: If set in the reverse direction, the pipe will be pulled out and grooving cannot be performed.

To avoid accidents, injury and/or damage, take special care to prevent the pipe from dropping while you are working. Be sure to place even a short pipe on a pipe support.

5. Use the lock pins correctly. (Refer to Figs. 2 and 12)

When grooving, pull the head lock pin to set the head free. Operate the roller lock pin according to the type of pipe.

6. Use the pump correctly. (Refer to Pg. 8, 3. Operating the Pump)

Operating the pump too quickly may result in deformed grooves and damage to the machine. Make sure you use it correctly.

7. Stop using the pump if the warning LED lights up.

Stop using the pump if the RED LED above the switch comes on. Continuing to operate the pump when the warning LED is on will make the groove deeper and may damage the machine.

8. Check the dimensions of the groove with a gauge. (See Pg. 12, 7 Confirm groove dimensions)

After processing the pipe, be sure to check the dimensions of the groove with calipers, etc.

9. Place the machine on a flat surface.

Place the machine on a stable, flat area and fix the legs securely with thumbscrews. Using the machine in an unstable position may cause the machine to overturn. Never operate the unit in this manner.

3. MAIN PARTS, STANDARD SPECIFICATIONS, ACCESSORIES

NAMES OF EACH PART

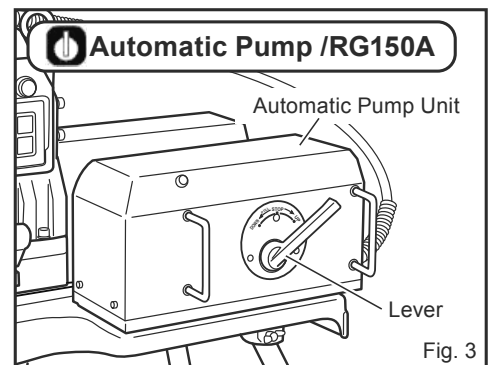
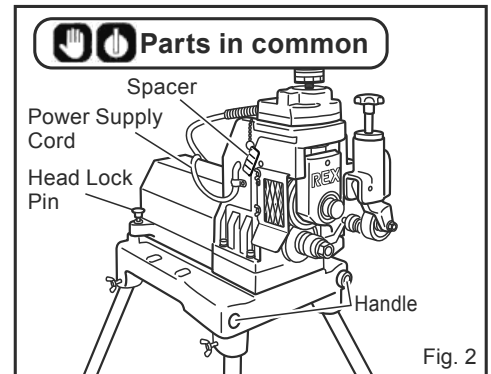
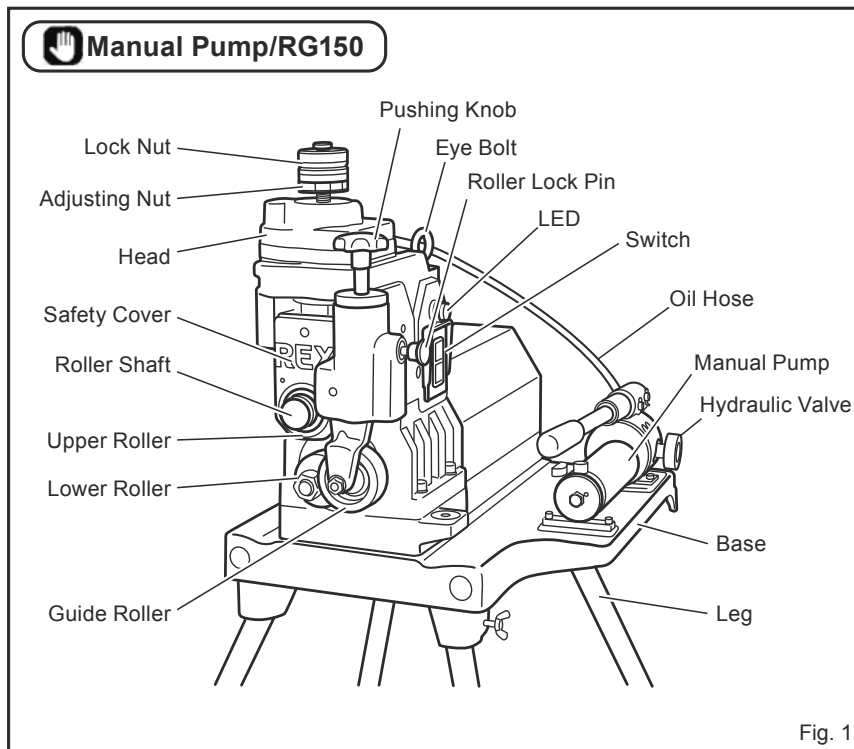

STANDARD SPECIFICATIONS

Model	RG150 (Manual Pump)	RG150A (Automatic Pump)
Application	Process roll grooves for piping steel pipes and stainless steel pipes	
Processing capacity	2" - 6" (50A - 150A)	
Applicable Pipe	Steel Pipe (Schedule 10 - 40)	
Minimum length of pipe required for grooving	25A - 150A : 120mm 200A - 300A : 130mm	
Motor	700W single-phase series motor	
Power Supply	220 - 230V (50/60Hz)	220 - 230V (50Hz) / 110V (50Hz)
Rotation Speed	49 min ⁻¹	
Dimensions (main unit)	685(L) x 490(W) x 625(H) mm	
Weight (main unit)	75kg	85kg

Table 1

STANDARD ACCESSORIES

Tool Box, Spirit Level, Spanner, T-Wrench, Grease

OPTIONAL ACCESSORIES

Pipe Support (1" - 6", 8" - 12")
 Roller set (1" - 1½", 8" - 12", 10" - 12" Sch40, 14" - 16" Sch10)
 Roller set for thin wall stainless steel (1" - 1½", 2" - 3", 4" - 6")
 Groove Gauge (1", 1¼", 1½", 2", 2½", 3", 4", 5", 6")
 Circumference Groove Gauge

4. GETTING READY

1. Setting Up

Attaching the legs (Fig. 4)

Insert each of the four legs into the sockets in the base of the machine, and tighten the thumb screws on the outside of the sockets to fix the legs in position. (Fig. 4)

⚠ CAUTION

- Be sure to put the machine on a flat surface.
- Tighten the thumb screws firmly and check that the legs do not come out.

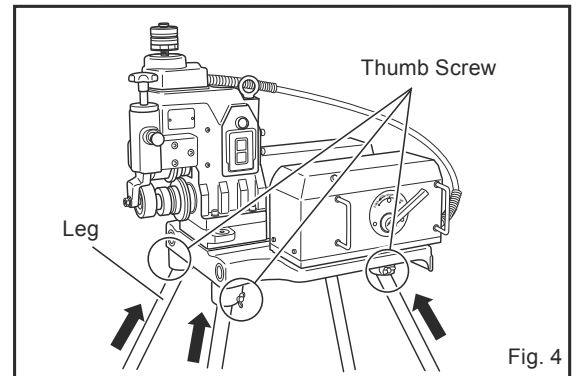

Changing the rollers. (Fig. 5)

Make sure you use rollers that match the pipe size. When delivered, the machine is fitted with rollers for 2" - 6" steel pipe. When rollers are worn out, or when processing other pipe sizes like 25A - 40A (including spindle) and 200A - 300A, replace the rollers with the following procedure.

⚠ WARNING

When changing the rollers, be sure to pull out the power cord so as to prevent the machine from starting abruptly, which could cause accident and injury.

Mark	Applicable Pipe
1 - 1½	1" - 1½" (25A - 40A)
2 - 6	2" - 6" (50A - 150A)
8 - 12	8" - 12" (200A - 300A)
8 - 12/10 - 12	10" - 12" (250A - 300A)
14 - 16	14" - 16" (350A - 400A)

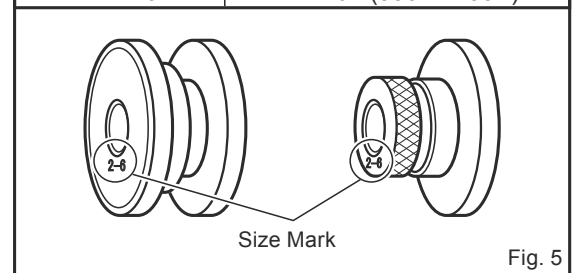

Removing the rollers

1. Loosen the thumb screws and remove the safety cover.
 2. Remove the upper roller by loosening its fitting screws and pulling out the roller shaft. (Fig. 6)
 3. Pull the lower roller forward by loosening the hexagon nut on the main shaft and removing the washer. (Fig. 7)
- * In case of replacing 1" - 1½" rollers, it is necessary to replace the main shaft as well. Please refer to the operation manual of 1" - 1½" roller set.

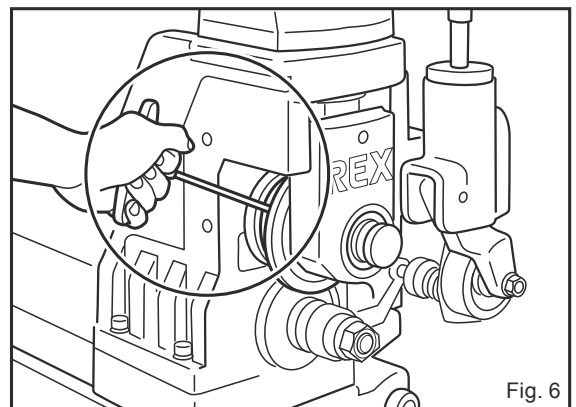

Reinstalling the rollers (reverse the procedure above).

1. Place the lower roller onto the main shaft, and tighten the hexagon nut firmly.
2. Align the key on the upper roller with its corresponding slot on the roller shaft and lock securely with the fitting screw.
3. Replace the safety cover.

* Before reinstalling the rollers, use a rag to wipe away any waste from the inside of the roller and the shaft. Apply grease over the entire surface of the upper roller shaft and to the inside of the lower roller.

* Change the upper and lower rollers as a matching set.

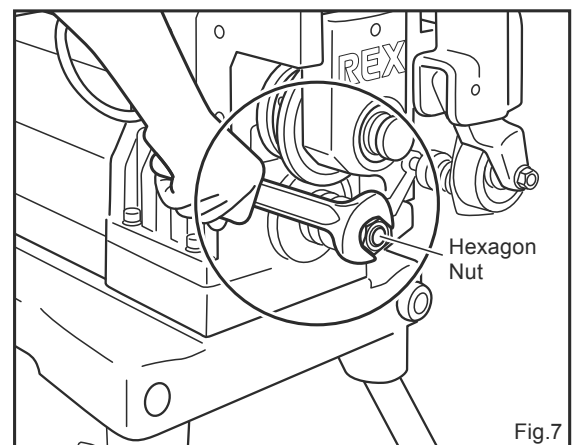

4. GETTING READY

2. Setting Up the Pipe

Adjusting the height of the pipe (Fig. 8)

1. Place the pipe to be processed on the lower roller, and use a pipe support(s) to support the other end. In case of long pipe, use two pipe supports.

CAUTION

To avoid accidents, injury and/or damage, take special care to prevent the pipe from dropping while you are working. Be sure to place even a short pipe on a pipe support.

2. When using a REX pipe support, rotating the knob on the pipe support changes the distance from the bearings. Rotate the knob so that the bearings form at an angle of about 120° to the centre of the pipe.

3. Turn the handle to adjust the height of the pipe support so that the pipe and the machine are level.

- Position the pipe so that the end contacts the collar of the lower roller. If the pipe end detaches from the collar, the groove will not be right. (Fig. 9)

* Check the machine is horizontal using the spirit level on the base processing surface. (Fig. 10, 11)

Adjusting the pipe swing (Fig. 11)

1. Set the pipe in position by swinging it by about 3° in the direction shown in Fig. 11. Adjust the swing of the pipe by positioning the pipe support.

* The handle is angled 5° from the centre line. Use this as a point of reference.

CAUTION

If the pipe is set straight or in the reverse position, the pipe may be drawn out and drop off the rollers, resulting in accident or injury. Be sure to position the pipe in the direction shown in Fig. 11

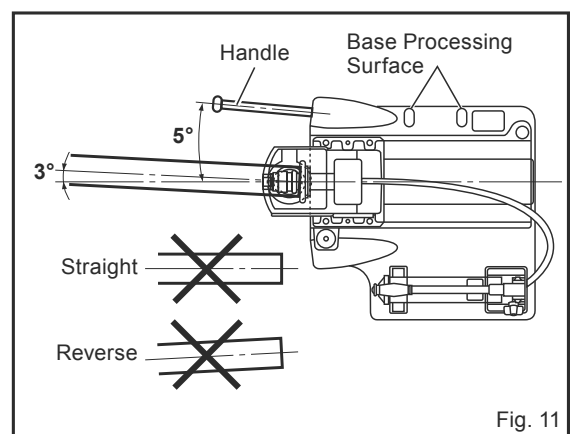
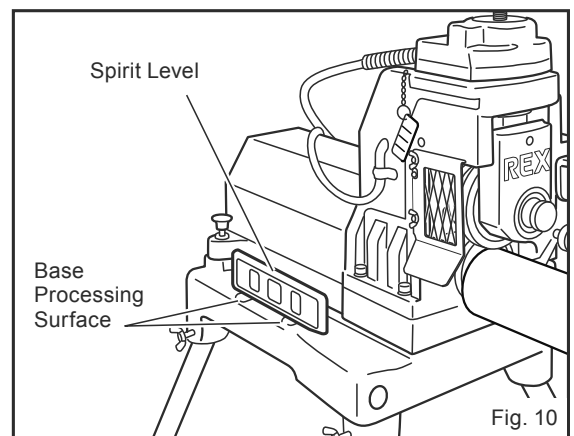
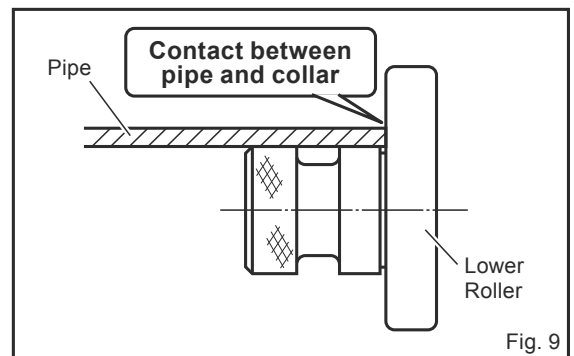
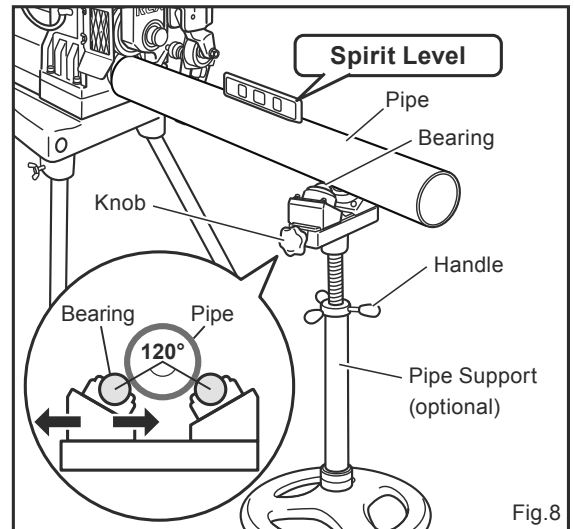

4. GETTING READY

Operating the head lock pin

1. Unlocking the head lock pin (Fig. 12)

Pull the red knob on the head lock pin up to release the head.

⚠ CAUTION

If force is applied to the head when releasing it, the head may move abruptly, which is liable to cause an accident or injury such as getting your fingers pinched.

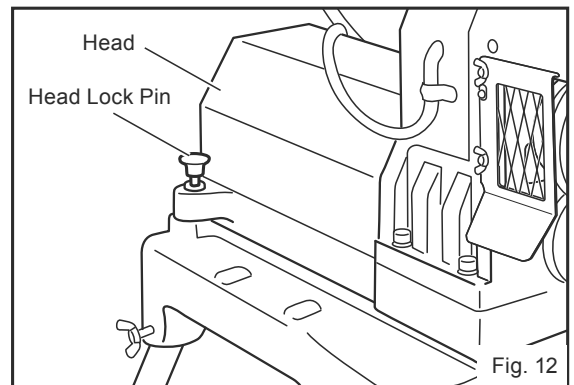

Fig. 12

2. Roller lock pin (Fig. 13)

Operate the roller lock pin according to the pipe to be processed. (Table 2)

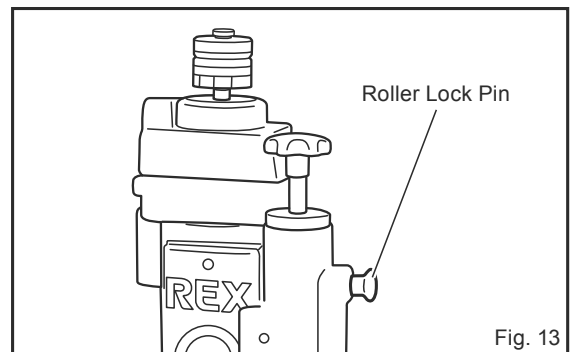

Fig. 13

Operating the roller lock pin according to the type of pipe

Pipe to be processed	Position of the roller lock pin	Action/Effect
- Schedule 10 - 30	Pull	A cushioning mechanism is applied to the guide roller, reducing flares at the end of the pipe. Used for comparatively soft pipes.
- Schedule 40 - STD	Push	A locking mechanism is applied to the guide roller, preventing the pipe from falling out. Used for comparatively hard pipes.

Thin wall stainless steel pipe, please do not use guide roller.

Table 2

Automatic Alignment

The machine is provided with a mechanism that automatically aligns the pipe and the centre of the main unit. This corrects any misalignment of the pipe and the main unit by moving the head freely in a horizontal direction (max. swing about 8°). By rotating the pipe, the head moves automatically to align the pipe and the main unit. Flares at the end of a pipe can be minimised since misalignment of the pipe and the head is corrected.

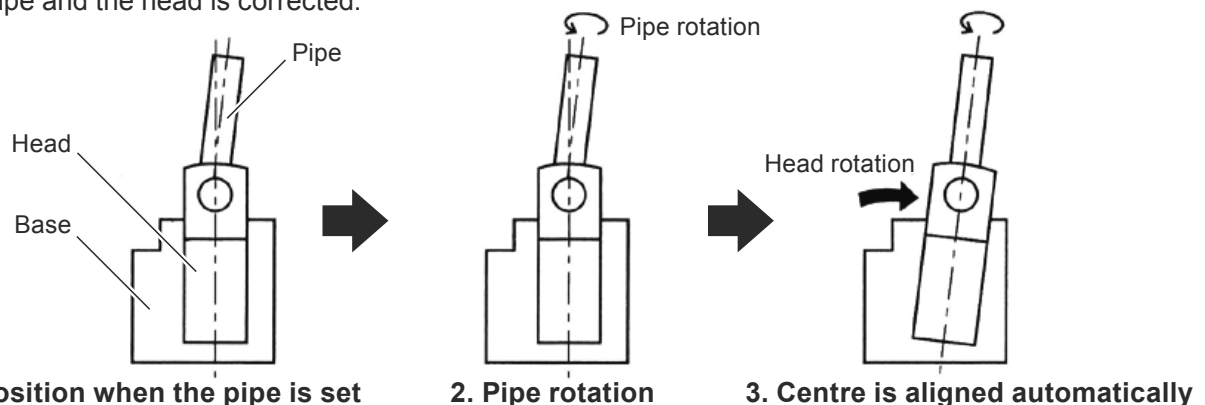

1. Position when the pipe is set

2. Pipe rotation

3. Centre is aligned automatically

Fig. 14

4. GETTING READY

3. Operating the Pump

The pumps on the manual (RG-150) and the automatic (RGA-150) units are operated differently. Read the operation instructions for the model you purchased carefully and be sure to use in the correct way.

⚠ WARNING

The pump generates high pressure. When operating the machine stay alert and take care not to get your fingers caught in the rollers etc.

👉 Operating Manual Pump (RG150) Fig. 15

1. After checking the hydraulic valve is closed, move the pump handle up and down to lower the upper roller.
2. When raising the roller, loosen the hydraulic valve on the hydraulic pump and release the pressure.

👉 Operating Automatic Pump (RG150A) Fig. 16

The roller is raised or lowered using the lever on the left hand side of the unit.

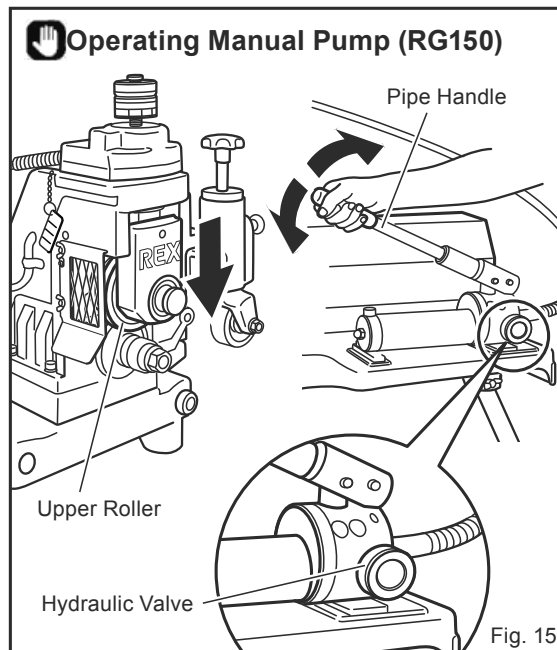

Operating the Automatic Pump

Lever position	Movement of pump and upper roller
Down	<p>When the hydraulic pump is operated, hydraulic pressure is applied to the cylinder and the upper roller is lowered. At this time, a green LED lights up.</p> <p>* From Stop position the lever is locked for safety. Pull the lever outwards gently to release the lock and then push into the Down position.</p> <p>* As in the manual pump model, when the valve is closed and one moves the pump handle up and down it is released.</p>
Stop	<p>The hydraulic pump stops and the upper roller stops where it is. At this time, hydraulic pressure is applied to the cylinder.</p> <p>* This corresponds to closing the valve in the manual model.</p>
Up	<p>Hydraulic pressure is released and the upper roller is raised.</p> <p>* When grooving, hydraulic pressure is increased. By pushing down the lever fairly strongly, hydraulic pressure is released.</p> <p>* This corresponds to loosening the valve and releasing the hydraulic pressure in the manual model.</p>

Table 3

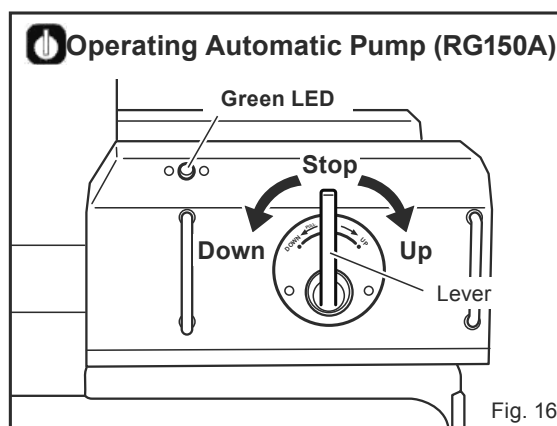

* The automatic pump has two specifications – 220/230V-50Hz and 110V-50Hz. Always use the correct voltage and frequency.

5. OPERATION GUIDE

1. Adjusting groove depth

1. Loosen the lock nut. (Fig. 17)

 Procedures in common

- Loosen the lock nut as far as the top of the screw, and similarly loosen the adjusting nut.

2. Adjusting the position of the upper roller (Fig. 18)

 Manual Pump /RG150

- Loosen the hydraulic pump valve and lift the pump handle up and down several times to gently engage the roller with the pipe.

 Automatic Pump /RG150A

- While pulling the lever gently towards you, push the pump lever down to the left so that the pump lowers the upper roller. Once the roller contacts the pipe, immediately return the lever to the centre (STOP) position.

- * When the roller touches the pipe, the pump makes a scraping sound. (sometimes there is no sound)

3. Adjustment of groove depth (Fig. 19)

 Procedures in common

- Put the spacer on the adjusting plate, and lightly tighten with the adjusting nut. Then, tighten the lock nut a little more to lock the adjusting nut.

- * Hold the spacer where the thickness matches the size of the pipe to be processed. (Fig. 20)

- * The spacer is used as a reference for adjusting groove depth. After trial processing, adjust the adjusting nut more finely to the appropriate groove depth.

4. Finishing up the adjustment of groove depth.

 Manual Pump /RG150

- Loosen the hydraulic valve, and remove the spacer from the adjusting plate.

 Automatic Pump /RG150A

- Pull the lever to the right (upwards) to release the hydraulic pressure and raise the upper roller. Once the roller is raised, return the lever to the STOP position, and remove the spacer from the adjusting plate.

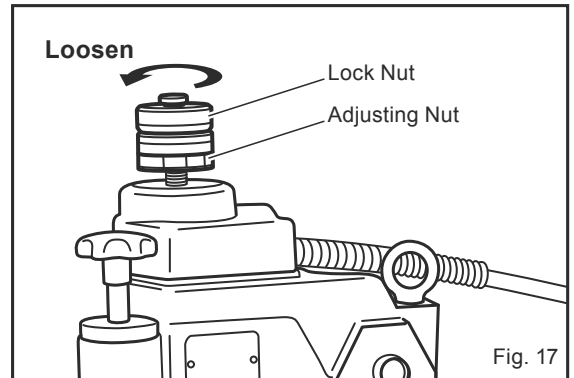

Fig. 17

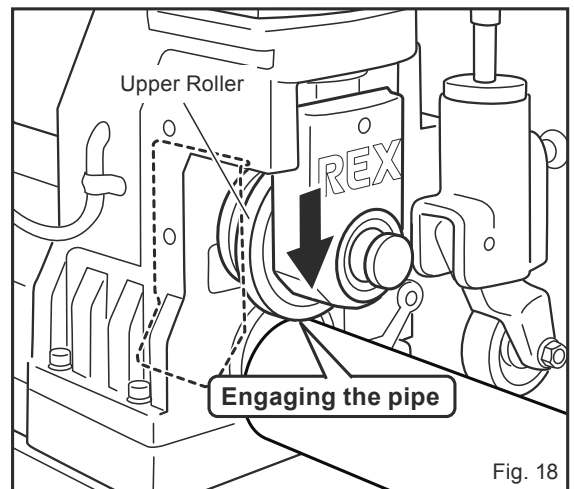

Fig. 18

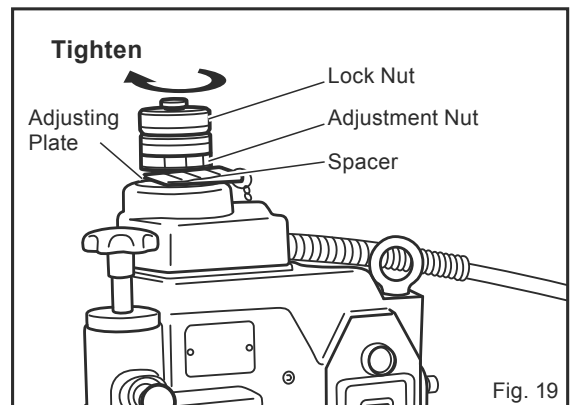

Fig. 19

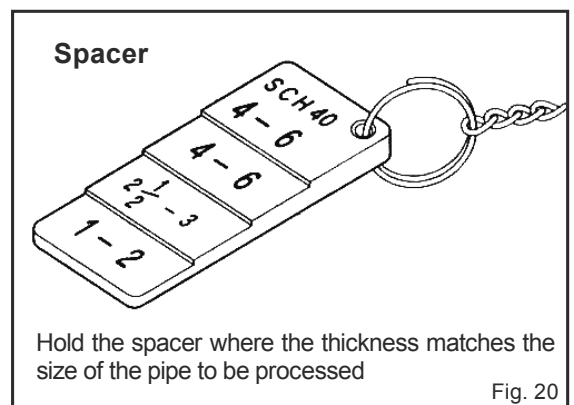

Fig. 20

5. OPERATION GUIDE

2. Grooving

1. Preparing to process the pipe (Fig. 21)

Manual Pump /RG150

- Tighten the hydraulic valve, start pumping, lightly grip the pipe with the upper roller and press again.

Automatic Pump /RG150A

- Lower the lever into the DOWN position, lightly press the pipe with the upper roller and return the lever to the STOP position.

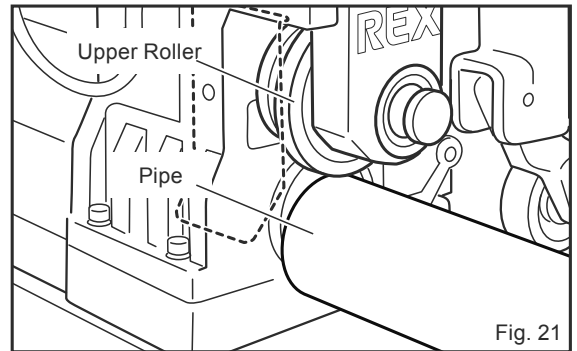

Fig. 21

2. Adjusting the guide roller (Fig. 22)

Procedures in common

- Rotate the push knob on the guide roller to lightly bring the guide roller into contact with the pipe. Now, tighten the knob a further half turn (1 full rotation in the case of 220A ~ 300A) to press the guide roller into the pipe.

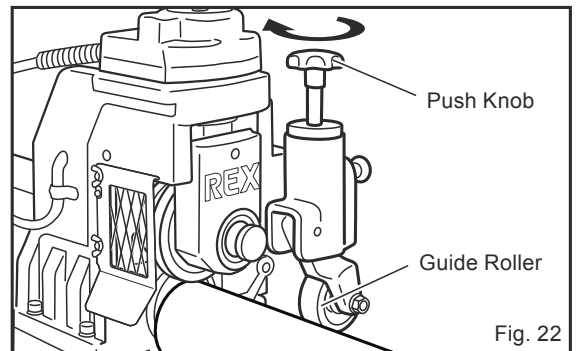

Fig. 22

3. Adjusting the head (Fig. 23)

Procedures in common

- Turn the machine switch ON, and allow the pipe to rotate several times. As the pipe rotates, the machine head simultaneously starts moving and aligns automatically. As it does, check the pipe cannot come out.

* If the pipe comes out, loosen the hydraulic valve immediately and turn the machine OFF. (Push the lever on the auto pump over to the UP position.) Tighten the guide roller push knob a little more, and check again.

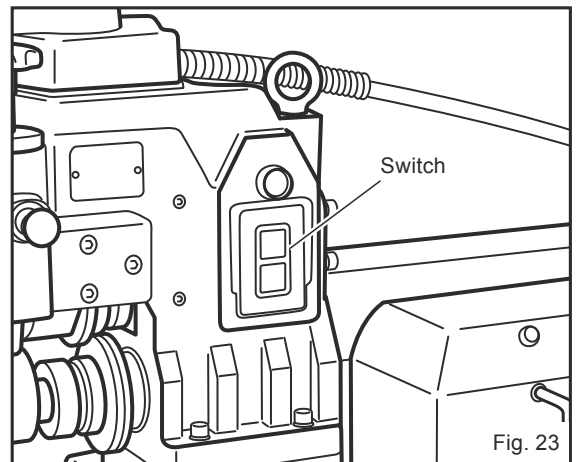

Fig. 23

4. Using the Foot Switch (Fig. 24)

Operation of the foot switch

The foot switch has three positions: upper, centre and lower.

- Upper:** OFF
- Centre:** ON
- Lower:** EMERGENCY STOP

The foot switch has a mechanism by which pressing the pedal to the lower position will automatically lock the switch and the machine will stop working immediately. Then to turn it on again, press the button switch on the side of the foot switch housing.

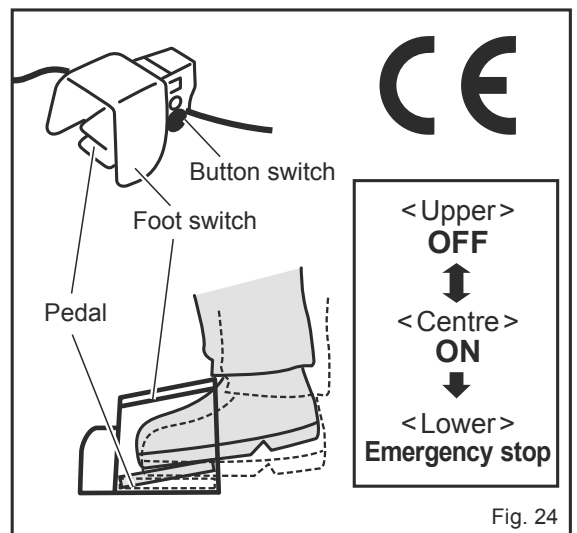

Fig. 24

5. OPERATION GUIDE

5. Grooving(Fig. 25, 26)

Manual Pump /RG150

- Operate the hydraulic pump to start processing the groove. Refer to the table below (Fig. 25)

SGP Schedule 10-40 STD	1 – 6" (25A – 150A)	Push the handle once for each rotation of the pipe.
Schedule 40 STD	8 - 12" (200A - 300A)	Push the handle once for every two rotations of the pipe.

Table 4

- * If you operate the handle too quickly, the pipe may be deformed or the machine may be damaged. Be sure to operate it correctly.

Automatic Pump /RG150A

- Turn the lever into the DOWN position, and start processing the groove.

6. Finishing up (Fig. 27)

- When the adjusting nut touches the adjusting plate, the red LED lights up.

Manual Pump /RG150

- When the LED lights up, turn the lever to STOP, allow the pipe to rotate once, and turn the switch to OFF.

Automatic Pump /RG150A

- When the LED lights up, turn the lever to STOP, allow the pipe to rotate once, and turn the switch to OFF.

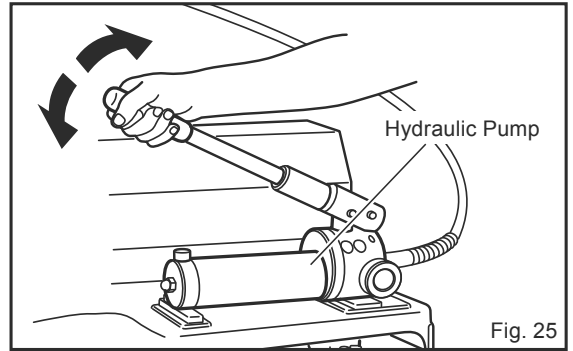

Fig. 25

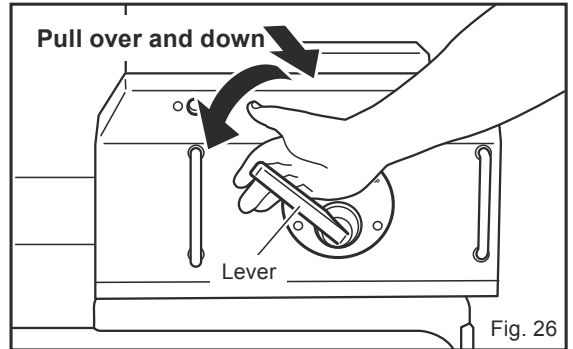

Fig. 26

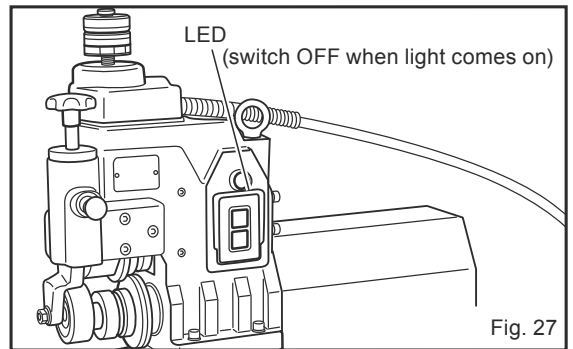

Fig. 27

3. CONFIRM GROOVE DIMENSIONS

1. Confirm groove depth (G dimension) (Fig.28-29)

- Check the groove depth with a groove gauge. The gauge has two measuring points, A (minimum diameter) and B (maximum diameter). Check the table below.

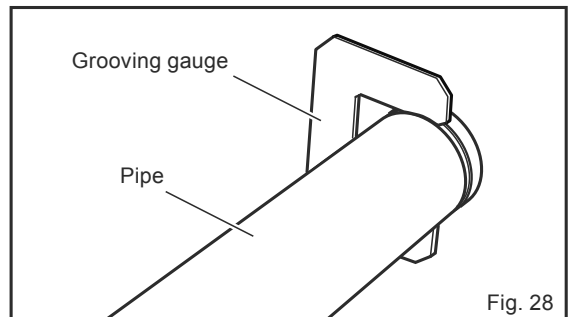

Fig. 28

Check the groove gauge	Groove depth	
Groove goes through B but not A.	The groove depth is appropriate.	OK
Groove does not go through B.	The groove depth is too shallow.	×
Groove goes through A.	The groove depth is too deep.	×

Table 5

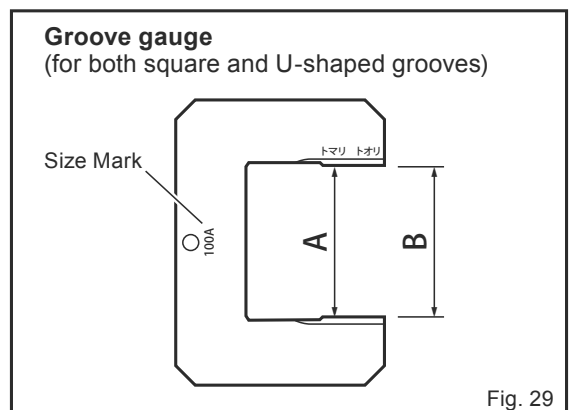
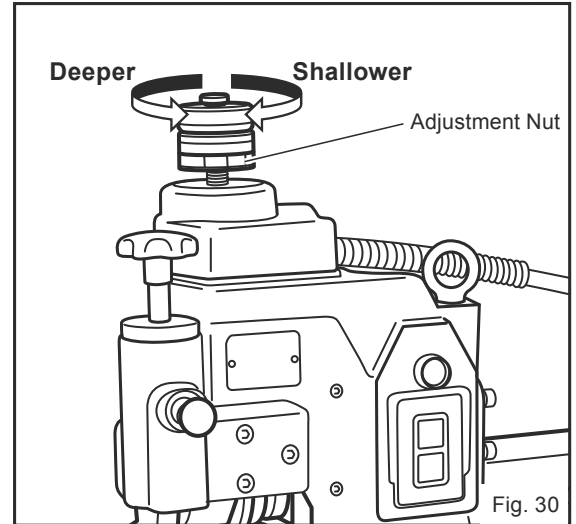

Fig. 29

5. OPERATION GUIDE

- * Since pipes may be somewhat deformed, check all around the pipe with the gauge.
- * Check the dimensions with a caliper before using the groove gauge as there is a possibility that the dimensions of the groove gauge do not appear due to wear or deformation.
- * If the groove is too shallow, turn the adjusting nut anticlockwise to make the groove deeper. If the groove is too deep, turn the adjusting nut clockwise to make the groove shallower. Depth can be adjusted with the adjustment nut (approx.0.3mm per mark on the scale). (Fig. 30)



2. Check the L and W dimensions with a caliper.

Pipe Size	Dimensions (mm)			
	OD Pipe Outside Diameter	L Gasket seat width	W Groove Width	G Groove Diameter (*Circumference)
1" (25A)	34.0	16 ^{+0.4} _{-0.9}	7.1 ±0.8	30.4 ⁺⁰ ₋₁
1¼" (32A)	42.7	16 ^{+0.4} _{-0.9}	7.1 ±0.8	39.1 ⁺⁰ ₋₁
1½" (40A)	48.6	16 ^{+0.4} _{-0.9}	7.1 ±0.8	45.0 ⁺⁰ ₋₁
2" (50A)	60.5	16 ^{+0.4} _{-0.9}	8.7 ±0.8	56.9 ⁺⁰ ₋₁
2½" (65A)	76.3	16 ^{+0.4} _{-0.9}	8.7 ±0.8	72.2 ⁺⁰ ₋₁
3" (80A)	89.1	16 ^{+0.4} _{-0.9}	8.7 ±0.8	84.9 ⁺⁰ ₋₁
4" (100A)	114.3	16 ^{+0.4} _{-0.9}	8.7 ±0.8	110.1 ⁺⁰ ₋₁
5" (125A)	139.8	16 ^{+0.4} _{-0.9}	8.7 ±0.8	135.5 ⁺⁰ ₋₁
6" (150A)	165.2	16 ^{+0.4} _{-0.9}	8.7 ±0.8	160.8 ⁺⁰ ₋₁
8" (200A)	216.3	19 ±0.8	11.9 ±0.8	* 664.8 ⁺⁰ _{-3.1}
10" (250A)	267.4	19 ±0.8	11.9 ±0.8	* 825.0 ⁺⁰ _{-3.1}
12" (300A)	318.5	19 ±0.8	11.9 ±0.8	* 983.0 ⁺⁰ _{-3.1}
14" (350A)	355.6	23.8 ±0.8	11.9 ±0.8	*1099.7 ⁺⁰ _{-2.4}
16" (400A)	406.4	23.8 ±0.8	11.9 ±0.8	*1259.3 ⁺⁰ _{-2.4}

Table 6

* Please check the circumference gauge for the groove diameter (G) of pipe size 8" (200A) or more. The G dimension of 8" (200A) to 16" (400A) in the above table is the groove circumference.

5. OPERATION GUIDE

4. Pipe chamfer

- If necessary, the outer periphery of the pipe end face is cut with a disc grinder or the like to a size of C 0.3 - 0.5 mm. Please chamfer at 45°. There is a possibility of scratching the packing of the fitting when the edge is standing. (Fig. 31)

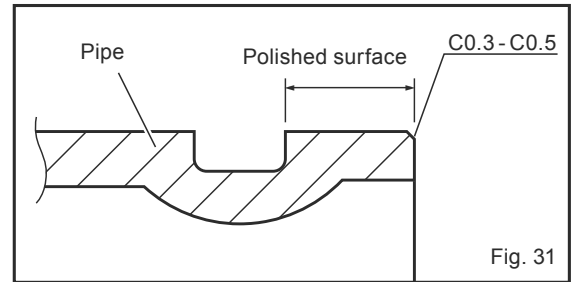

Fig. 31

5. Carrying the machine

1. Locking the head (Fig. 32)

- Push the head lock pin down, and check the head is locked.

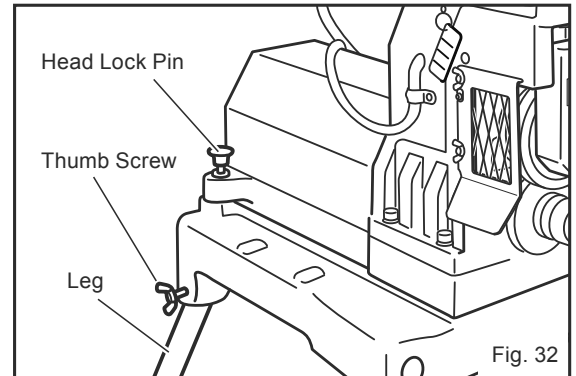

Fig. 32

2. Removing the legs (Fig. 33)

- Loosen the thumbscrews and remove the legs to carry the machine.

⚠ CAUTION

If the machine is moved without removing the legs, the legs might come off due to the screws becoming loose etc., which could lead to unexpected accidents and injuries.

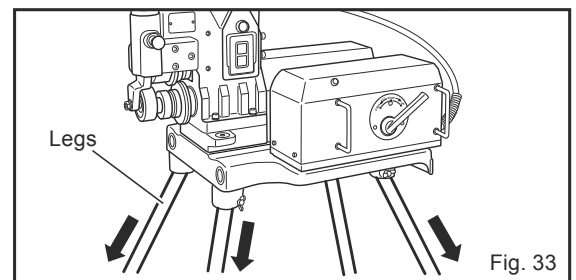

Fig. 33

3. Carrying

- To carry the machine, use a hoisting device, such as a crane. Use a hanging hook to hoist the machine using the eyebolt hole on the main body. (Fig. 34) Before connecting the hook, make sure that the eyebolt is fixed on the body and does not rotate. Do not connect the hanging hook to any part other than the eyebolt.

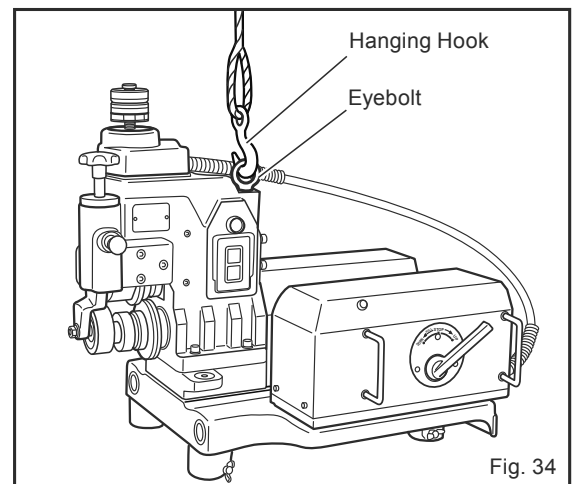

Fig. 34

- In case there is no hoisting device, have at least 4 people carry the machine by hand. To carry the machine, pull out the handles located in the base and then move the machine, holding it in the positions indicated by the arrows in the picture. (Fig. 35)

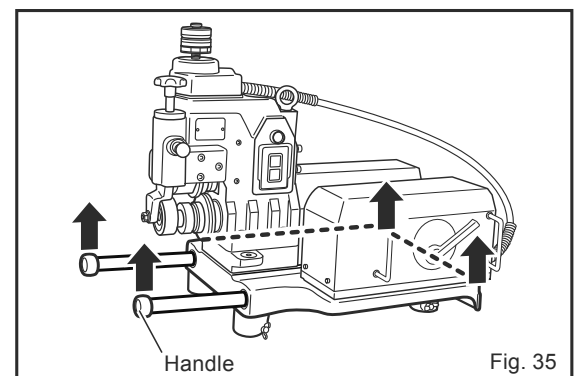

Fig. 35

6. SERVICING AND REPAIRS, TROUBLESHOOTING

If you find any abnormality with the product, please check the following points and contact the distributor from whom you bought the machine, or REX

WARNING

If any problems occur that are not dealt with below, do not attempt an overhaul or repair by yourself, but ask your distributor or our sales department to service the machine.

If repairs are attempted by anyone without the proper knowledge and skills, optimum performance will be impaired and accidents and injuries may occur.

Cause and measures when problems occur (TROUBLESHOOTING)

Problem	Possible cause	Corrective measures
Width of the groove is too narrow or too wide	Size of the upper/lower rollers does not match the size of the pipe	Match the rollers and the size of pipe
The distance between pipe end and groove (gasket seat width:G) is too large	Upper roller and /or Lower roller are worn	Change rollers
		Check if head lock pin is unlocked
		Check if guide roller presses the pipe too strongly
The groove zigzags	The pipe has been cut at an angle	Cut the pipe at right angle
The groove is not parallel with the pipe end	Pressure of the guide roller (resin roller) is too weak	Re-tighten the push knob and attach the guide roller to the pipe a little more strongly
Diameter of the groove varies around the circumference of the pipe	The pipe is not perfectly round	Use a circular pipe
	Speed of grooving is too fast	Operate the pump a little more slowly
The pipe end flare (bell mouth) is too large	The head lock pin is locked	Set the headlock pin free
	The resin guide roller's pressure on the pipe is too great	Loosen the push knob
	Size of the upper/lower rollers does not match the size of the pipe	Match the rollers and the size of pipe
	The pipe support is too high	Adjust height of the pipe support to make the pipe and the machine level
	Operation of the roller lock pin is incorrect	Operate according to the pipe
	Speed of grooving is too fast	Operate the pump a little more slowly
The pipe is drawn out from the roller while grooving	Pressure of the guide roller (resin roller) is too weak	Re-tighten the push knob, and attach the guide roller to the pipe a little more strongly
	The pipe is set without swinging it, or is in the reverse direction.	Set the pipe by swinging it into the normal direction
	The pipe support is too low	Adjust the height of the pipe support to make the pipe and the machine level
The pipe slips during processing and smooth rotation is not made	The lower roller knurling is clogged or worn	Remove clogging with wire brush, etc. or replace the lower roller
	Grooving speed is too fast	Operate the pump a little more slowly
Pumping action does not deepen the groove	The adjusting nut is too tight	Loosen the adjusting nut, and process again
	Air has got into the hydraulic hose	Open the oil feed port on the hydraulic pump and apply/release pressure about 5 times
	There is insufficient oil in the hydraulic pump	Replenish with general hydraulic oil (ISO#32)
	The pump valve and/or packing are damaged, and the pressure applied is insufficient	Ask for repairs
Oil leaks from the hydraulic system	Hose joint is loose	Re-tighten the joint
	The cylinder packing is damaged	Ask for repairs
LED does not light up when finished	The LED has gone, or is damaged	Ask for repairs
	The limit switch has slipped	
The motor does not rotate	Voltage is too low	Use correct power supply
	The carbon brushes are worn out	Replace the carbon brushes

Table 7

7 DAILY INSPECTION, MAINTENANCE

⚠ WARNING

Before inspecting the machine or carrying out maintenance, pull the plug out of the socket. If the machine were to suddenly start operating, it could result in accident or injury.

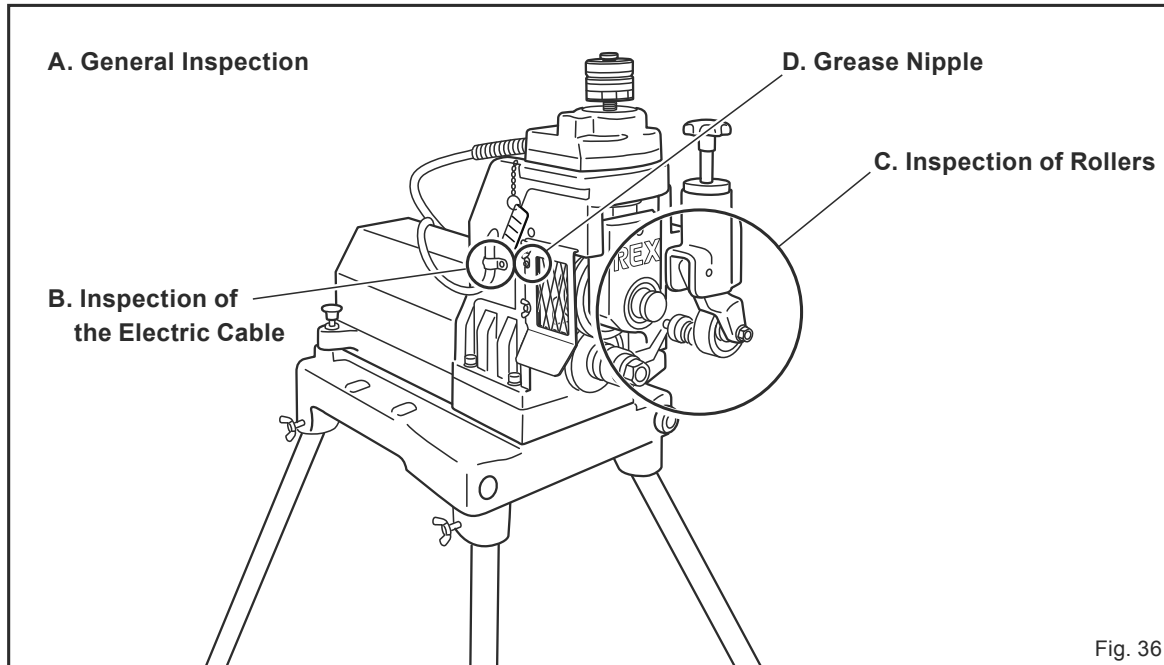

Fig. 36

1. Inspect all screws and nuts (A)

- Check all screws and nuts, and retighten if loose. In particular, check the screws on the upper roller and the nuts on the lower roller. If any of these are loose, the roller may be damaged. Check the screws on the legs are tight.

2. Inspect the electric cable, etc. (B)

- Check for damage to the plug and the power cord. Replace them if necessary. To prevent electric leakage or shock, ensure the machine is earthed.

3. Rollers inspection (C)

- Check that the rollers match the type of pipe being used. Normal grooving will not be possible if you use the wrong rollers.
- Check the rollers for chips and cracks. If the rollers are damaged, precision grooving will not be possible and the machine will be damaged. Replace with new or undamaged rollers.

4. Periodic lubrication (C) & (D)

Be sure to lubricate regularly to prevent burning and galling.

- When replacing rollers, apply grease to the entire shaft of the upper roller and the inside of the lower roller
- Once every 2 weeks, remove the upper roller and grease the bearings, and replenish the grease nipple (D) on the side of the machine.
- Please use KINGSTAR EP (NIPPON GREASE CO., LTD.) or equivalent for grease.

5. Clean after use (A)









- To prolong the life of the machine, be sure to clean the machine and rollers each time after use. Remember to clean the areas around the upper and lower rollers.

8. REQUESTING REPAIRS

This machine is produced with great precision. Should it not operate normally, never attempt to repair it yourself. Always ask your distributor or our sales department for repairs.
Please contact us if you need any parts or have any questions about REX products.

About the holding period of maintenance parts	Supply of maintenance parts of this product shall be 7 years after stopping manufacturing. However, electronic parts shall be for 5 years.
---	--

⚠ 9. EXPLANATION OF SYMBOLS

	<p>SAFETY INSTRUCTIONS Read and understand the operation manual before using the machine.</p>
	<p>RISK OF EAR INJURY Wear ear protection.</p>
	<p>RISK OF EYE INJURY Wear eye protection.</p>
	<p>LIFTING HAZARD Heavy object - mechanical lift only</p>
	<p>ELECTRICAL HAZARD This machine is to be operated by trained personnel only.</p>
	<p>CRUSH HAZARD Moving parts can cause serious injury. Keep hands clear while operating.</p>
	<p>ROTATING ROLLERS HAZARD Keep hands and fingers clear.</p>
	<p>CUT HAZARD Sharp edges can cause serious injury. Keep hands and fingers clear.</p>

Warranty and Liability

1. If the product fails during normal use conditions, free repair or service parts will be supplied free of charge as follows:
 - Free repair warranty period is one year from the date of purchase.
 - For repair and service parts supply, REX will decide the schedule, procedures, method, etc. by meeting with customers.
2. About repair charges.
 - When the warranty period has expired, all repair and service part supplies will be charged.
 - Warranty repair in the following cases, even within the warranty period, will be subject to repair.
 - (A) The machine has not been handled as instructed in this manual.
 - (B) The machine has been used for purposes other than those indicated in this manual.
 - (C) If the user does not follow repairs as instructed in this manual, and if user remodels it.
 - (D) Consumable parts.
 - (E) Extremely harsh usage.
3. REX holds no responsibility in the following cases:
 - (A) Malfunction or accidents due to fire, flooding, earthquakes, lightning strikes, other natural disasters, war, conflicts, riots, terrorism, pollution or abnormal voltage.
 - (B) When the machine is not handled according to this operation manual.
 - (C) In the case of misuse, or inappropriate repair or remodeling.
 - (D) When a malfunction or accident results from using a pipe shaped with the machine, or by leaving it lying around and/or if it is exposed to the elements.
 - (E) When a malfunction or accident results from using a pipe shaped with the machine either while or after connecting it to a joint.
4. Any costs incurred by the manufacturer shall not exceed the purchase price of the machine.

REX

REX INDUSTRIES CO., LTD.

Overseas Sales Dept. & Factory :

1-9-3, Hishiya-Higashi, Higashi-Osaka 578-0948 Japan

Tel.:+81-(0)72-961-9820 Fax.:+81-(0)72-961-9878

URL: <http://www.rexind.co.jp>