

REX Electric grooving series

LIGHT GROOVE

150DX

Parts List

As of October 2008



CONTENTS

1. Guide roller
2. Roller support
3. Main shaft-Switch
4. Head stock
5. Base
6. Automatic pump
/Hand pump (Old type)
7. Hand pump (New type)

REX

LightGroove150DX 「Guide roller」

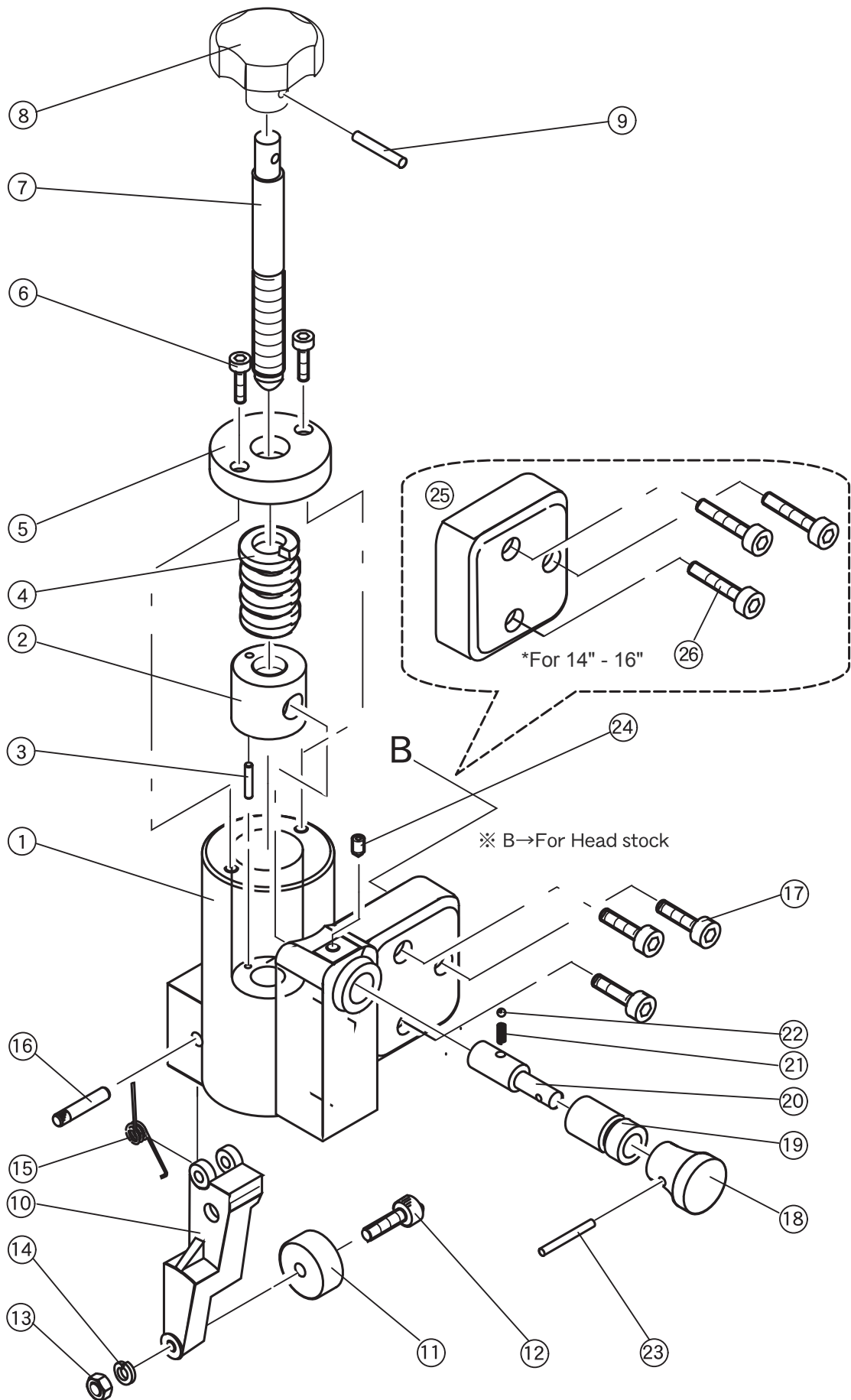

LIGHT GROOVE 150DX -1 (Guide roller)

No.	CE	Parts No.	Parts Name.	Set
1		RJ06	Roller guide	1
2		RJ33	Slide nut	1
3		WL46	Spring pin (M4x20)	1
4		RJA3	Slide nut spring	1
5		RJ34	Roller guide cap	1
6		W065	Socket head cap screw (M6x30)	2
7		RJ32	Roller feed screw	1
8		RJ92	Knob	1
9		WL54	Spring pin (M5x20)	1
10		RJ07	Roller holder	1
11		RX77	Roller	1
12		W00A	Socket head cap screw (M10x65)	1
13		WC10	Hexagon nut (M10)	1
14		WG10	Spring washer (M10)	1
15		RJ36	Kick spring	1
16		RJ35	Roller holder pin	1
17		W08F	Socket head cap screw (M8x30)	3
18		RJ41	Lock pin knob	1
19		RJ39	Lock pin guide B	1
20		RJ40	Lock pin B	1
21		H061	Notch spring	1
22		WQ04	Steel ball	1
23		WL36	Spring pin (M3x18)	1
24		W662	Socket set screw (cone) (M6x8)	1
25		RJLA	Roller guide spacer For 14 - 16"	1
26		W086	Socket head cap screw (For No.25/14 - 16") (M8x50)	3
27		0RJA1S	Guide Roller Assembly No.1-24	1

150DX -2 (Roller support)

2024.9.25

No.	CE	Parts No.	Parts Name.	Set
1		RJ04	Roller support	1
2		WZ52	Snap ring (1RTW52)	2
3		RJ52	Needle bearing (RNA6932)	1
4		RJ10	Roller shaft	1
5		RJ20	Roller key	1
6		RJ53	Needle bearing (RNA5928)	1
7		WZ45	Snap ring (1RTW45)	1
8		RJ58	Oil seal (AF1876E0)	2
9		RJL1	Upper roller2-6 EX	1
9		RJC1	Upper roller8-12 EX	1
9		RJF2	Upper roller1-1.1/2 EX	1
10		RJ57	Oil seal (AF2340F0)	2
11		W695	Socket head cap screw (cone p) (M10x15)	1
12		W065	Socket head cap screw (M6x30)	1

Light Groove 150DX 「Main shaft・ Switch」

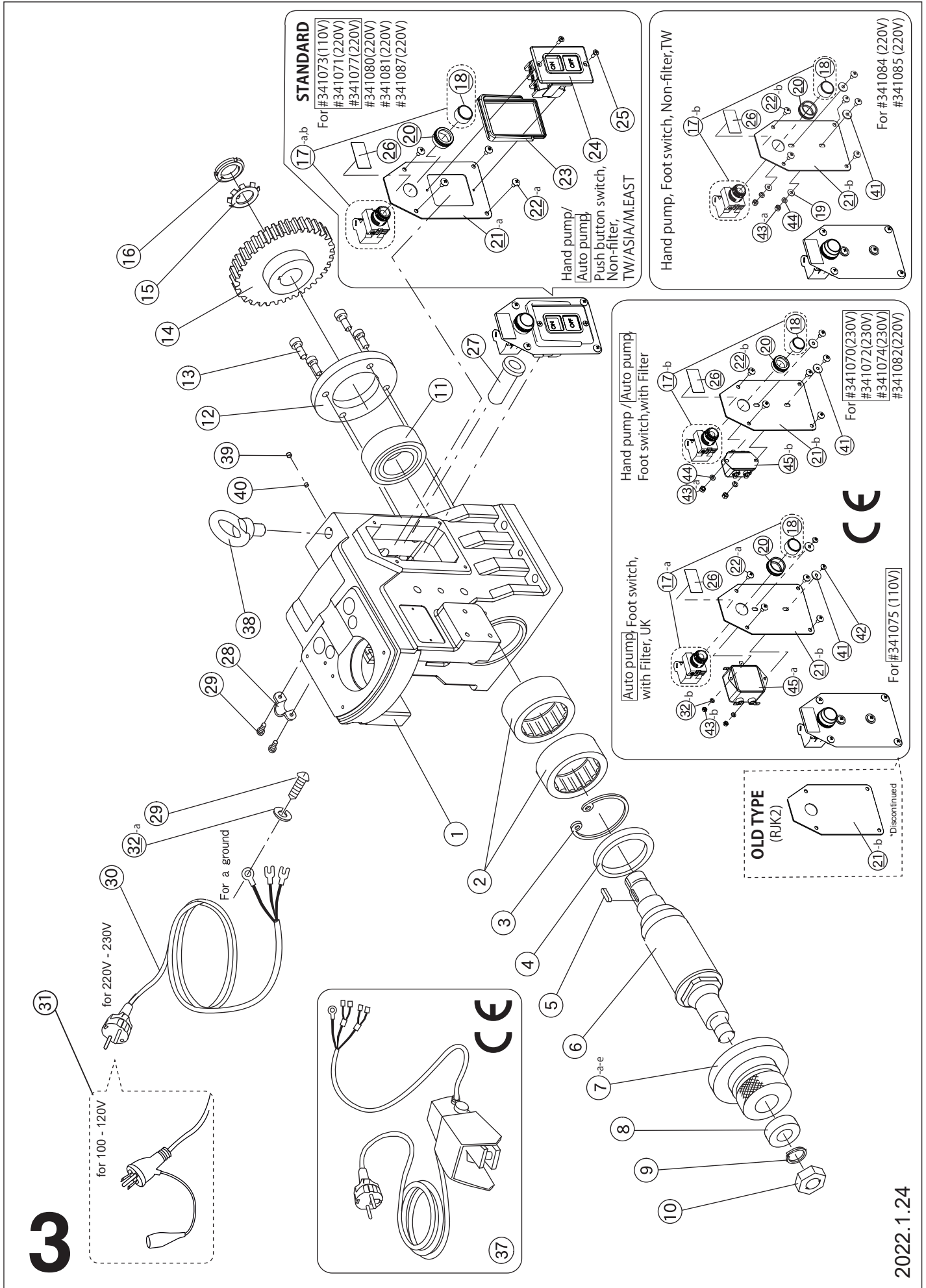

150DX -3 (Main shaft - switch)

2024.9.25

No.	CE	Parts No.	Parts Name.	Set
1		RJ03	Head stock	1
2		RJ51	Needle bearing (RNA6911)	2
3		WX80	Retaining ring C type (M80)	1
4		RJ56	Oil seal (DS63807)	1
5		RJ62	Main shaft key	1
6		RJ08	Main shaft	1
7		RJL2	Under roller 2-6 EX	1
7		RJC2	Under roller 8-12 EX	1
7		RN49	Under roller 10-12 EX	1
7		RJF3	Under roller 1-1.1/2 EX	1
8		RJ96	Roller washer	1
9		WG20	Spring washer (20)	1
10		WC20	Hexagon nut (M20)	1
11		RJ54	Ball bearing (5208CZZ)	1
12		RJ42	Bearing plate	1
13		W080	Socket head cap screw (M8x15)	4
14		RJ16	Main shaft gear	1
15		RJE3	Bearing washer (AW06)	1
16		RJE2	Bearing nut (AN06)	1
17		RJ60	Pilot lamp 100-120V	1
		RJK4	Pilot lamp 220-230V	
18			-Packing	1
19			-Collar cap	1
20		RJA4	Collar ring	1
21	×	RJ46	Switch plate	1
38	○	RJK2	Switch plate	1
22		W556	Truss head screw (M5x10)	4
23	×	RY33	Switch packing	1
24	×	RX46	Switch	1
25	×	W4A4	Oval head bolt (M4x12)	2
26		7A11	Lamp sticker	1
27		7021	Code bush	1
28		7098	Binder	1
29		W241	Round head machine screw (M4x8)	3
30		N122	Capyre cord (for 220-230V)	1
31		F153	Capyre cord (for 100-120V)	1
32		WG04	Spring washer (M4)	1
37	○	FSW1	Foot Switch	1
38		RJA5	Eye bolt (M16)	1
39		W762	Hex Socket Set Screw (Cup point M6x6)	1
40		RJA6	Brass pad (M6)	1
41		WI53	Flat washer (5x16x1.6)	2
42		W542	Truss head screw (M4x6)	2
43-a		WC05	Hexagon nut (M5)	2
43-b		WC04	Hexagon nut (M4)	2
44		WG05	Spring Washer (M5)	2
45-a		PM77	Electromagnetic filter 115V (CE)	1
45-b		RJP2	Electromagnetic filter 230V (CE)	1

Light Groove 150DX 「Head stock」

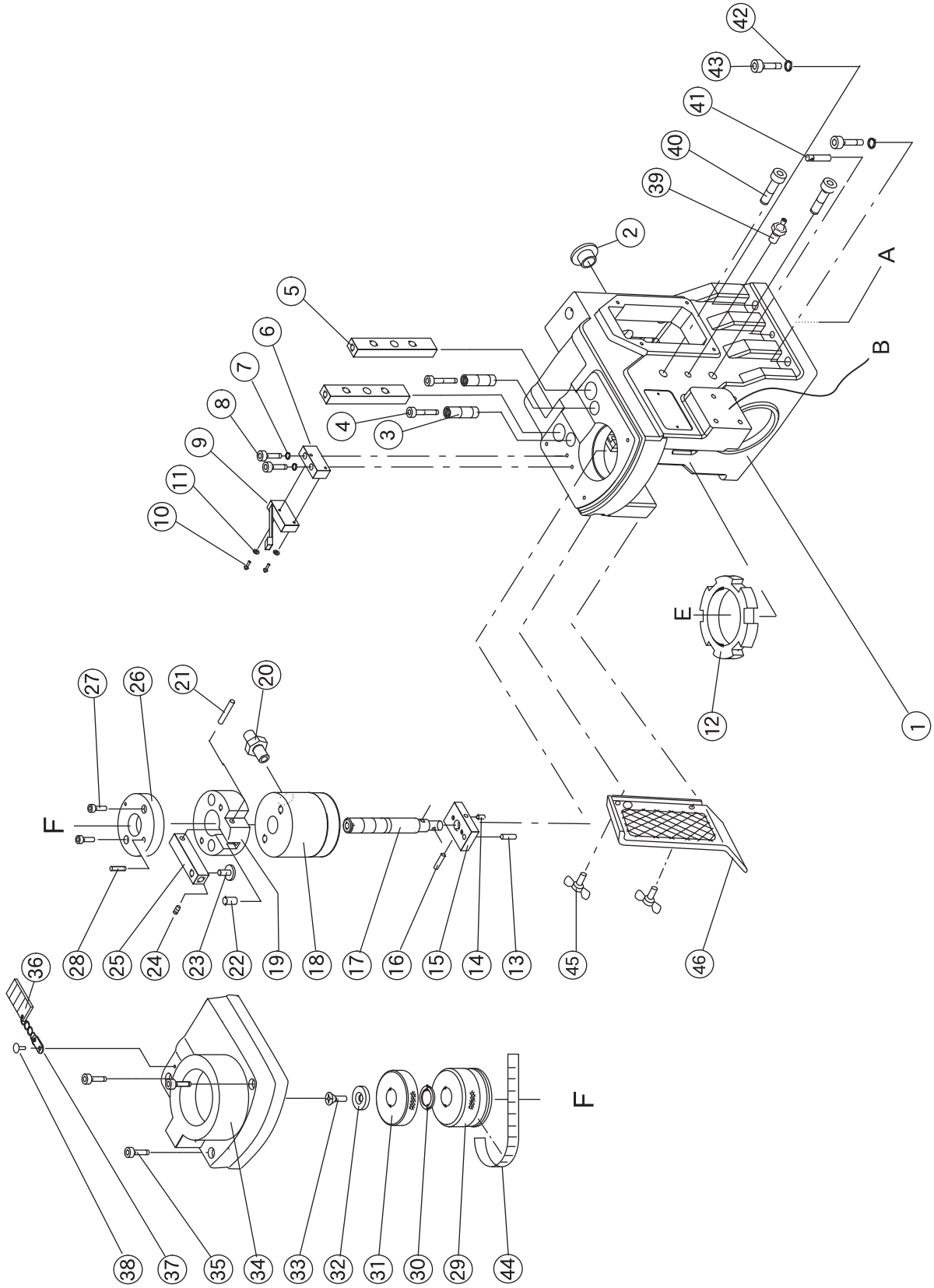

150DX -4 (Head stock)

2024.9.25

No.	CE	Parts No.	Parts Name.	Set
1		RJ03	Head stock	1
2		RX28	Base stopper (25mm/Black) *2023.9～	Old No. 9064(Gray) 1
3		RJ64	Return spring	2
4		W011	Socket head cap screw	(M10x110) 2
5		RJ09	Slide key	2
6		RJ28	Limit plate	1
7		WG06	Spring washer	(M6) 2
8		W065	Socket head cap screw	(M6x30) 2
9		RJ59	Limit switch	1
10		W237	Round head machine screw	(M3x15) 2
11		WG03	Spring washer	(M3) 2
12		RJ15	Cylinder nut	1
13		WL44	Spring pin	(M4x16) 1
14		W753	Socket set screw(cup p)	(M5x8) 2
15		RJ12	Joint plate	1
16		WL57	Spring pin	(M5x35) 1
17		RJ11	Cylinder shaft	1
18		RJ49	Cylinder	1
19		RJ26	Lever holder	1
20		RJ77	Coupling	(FZS-2N) 1
21		4072	Frame stop pin	1
22		RJ79	Lever spring	1
23		RJ30	Bush bolt	1
24		W990	Socket set screw	(M5x8,SBCP5-8) 1
25		RJ27	Switch lever	1
26		RJ25	Cylinder plate	1
27		W062	Socket head cap screw	(M6x16) 2
28		RJ68	Bush pin	1
29		RJ13	Stopper nut	1
30		WH20	Wave washer	(M20) 1
31		RJ17	Lock nut	1
32		RJ99	Adjustment washer	1
33		W357	Flat head screw	(M8x12) 1
34		RJ05	Cylinder case	1
35		W068	Socket head cap screw	(M6x45) 3
36		-	Spacer	only delivered as product 1
37		U577-3	Chain stop washer	Old No.4202 1
38		W4A8	Oval head cap screw	(M4x6) 1
39		RJ69	Grease nipple	2
40		W065	Socket head cap screw	(M6x30) 4
41		RJ29	Gauge pin	2
42		WG10	Spring washer	(M10) 4
43		W004	socket head cap screw	(M10x40) 4
44		6A63	Size sticker	1
45		WA67	Wing screw	2
46		RJL3	Safety cover	1

Light Groove 150DX 「Base」

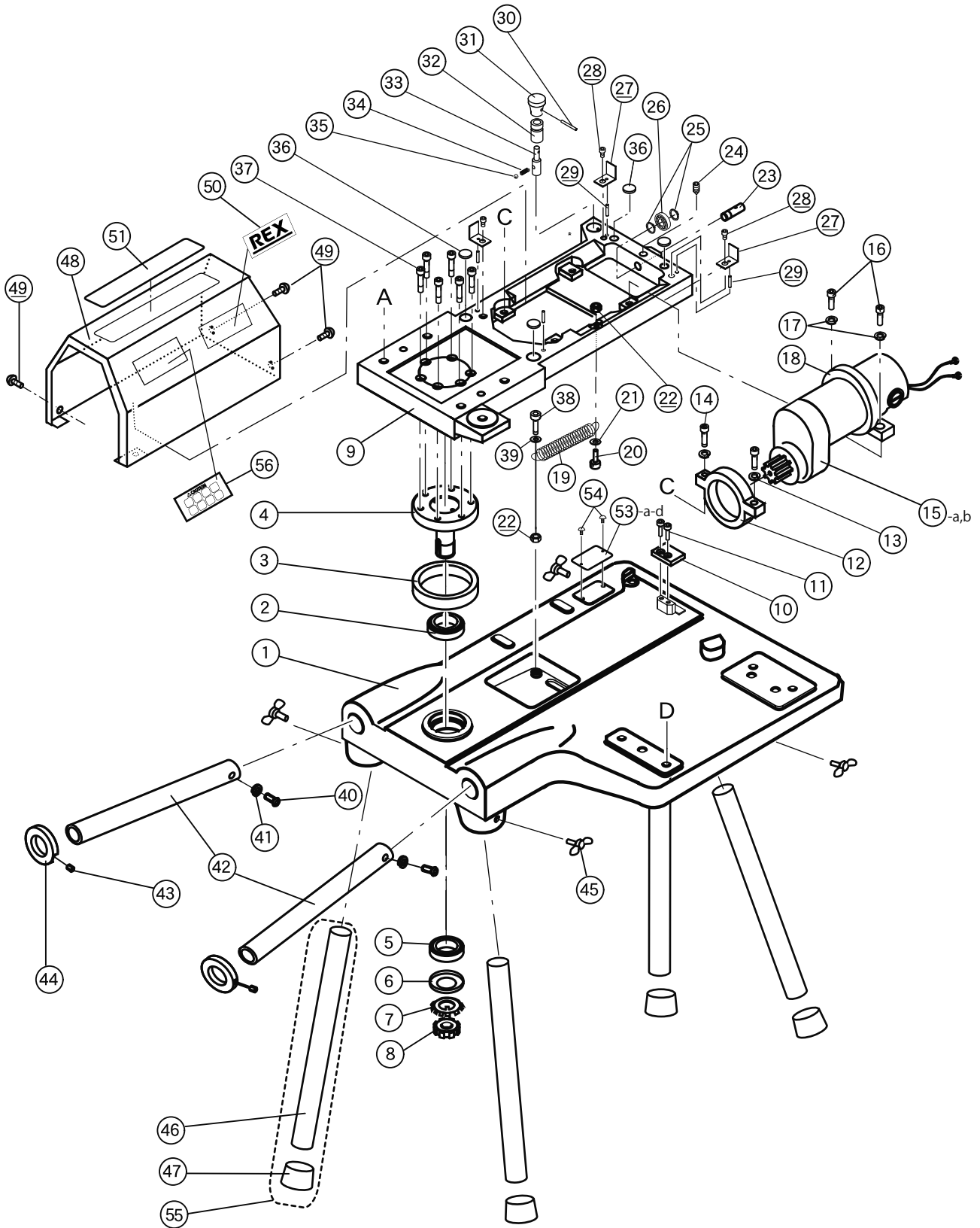

No.	CE	Parts No.	Parts Name.	Set
1		RJ01	Base	1
2		RJA1	Roller bearing (30208)	1
3		RJ31	Dust sponge	1
4		RJ14	Rotation shaft	1
5		RJA2	Roller bearing (30207)	1
6		RJ61	Ring	1
7		RJE4	Bearing washer (AW07/Black)	1
8		RJE1	Bearing nut (AN07)	1
9		RJ02	Circular base	1
10		RJ22	Bearing guide	1
11		W080	Socket head cap screw (M8x15)	2
12		RJ18	Motor flange	1
13		WG08	Spring washer (M8)	2
14		W084	Socket head cap screw (M8x35)	2
15		RJ48	Motor 100V-120V	1
		RJK3	Motor 220V-230V	
16		W083	Socket head cap screw (M8x25)	2
17		WG08	Spring washer (M8)	2
18		RJ21	Silencer sponge	1
19		RJ65	Base spring (H16-03)	1
20		W063	Socket head cap screw (M6x20)	1
21		WI81	Plain washer (M8)	1
22		WC06	Hexagon nut (M6)	2
23		RJ24	Bearing pin	1
24		W665	Socket set screw (cone p) (M6x15)	1
25		WW12	Retaining ring C type (12)	2
26		I202	Ball bearing (6201ZZ)	1
27		RJ23	Cover fixed plate	3
28		W060	Socket head cap screw (M6x10)	3
29		WL34	Spring pin (M3x12)	4
30		WL36	Spring pin (M3x18)	1
31		RJ41	Lock pin knob	1
32		RJ37	Lock pin guide A	1
33		RJ38	Lock pin A	1
34		H061	Notch spring	1
35		WQ04	Steel ball (M4)	1
36		RJ95	Rubber washer	4
37		W083	Socket head cap screw (M8x25)	6
38		W065	Socket head cap screw (M6x30)	1
39		WI62	Plain washer (M6)	1
40		W251	Round head machine screw (M5x8)	2
41		WG05	Spring washer (M5)	2
42		RJ44	Handle	2
43		W752	Socket set screw (cup p) (M5x6)	2
44		RJ45	Handle knob	2
45		RJ76	Wing bolt (cone plate) (M8x30)	4
46		N121	Pipe stand	4
47		N125	Lag cap	4
48		RJ19	Motor cover	1
49		W567	Truss head screw (M6x12)	3
50		RJD7	REX sticker	1
51		7A09	Warning and Instruction sticker	1
53	×	RJM3	Name plate 220V	1
53	×	RJM4	Name plate 110V	1
53	○	RJM1	Name plate CE-230V	1
53	○	RJM2	Name plate CE-110V	1
54		WN34	Rivet (M4x5)	4
55		N121C	Pipe stand(N121) with Lag cap (N125)	1pcs/set
56	○	1T07	CE Caution Label	1
57		RJD1	Tool Box T-360	1

Light Groove 150DX 「Pump」

Automatic pump

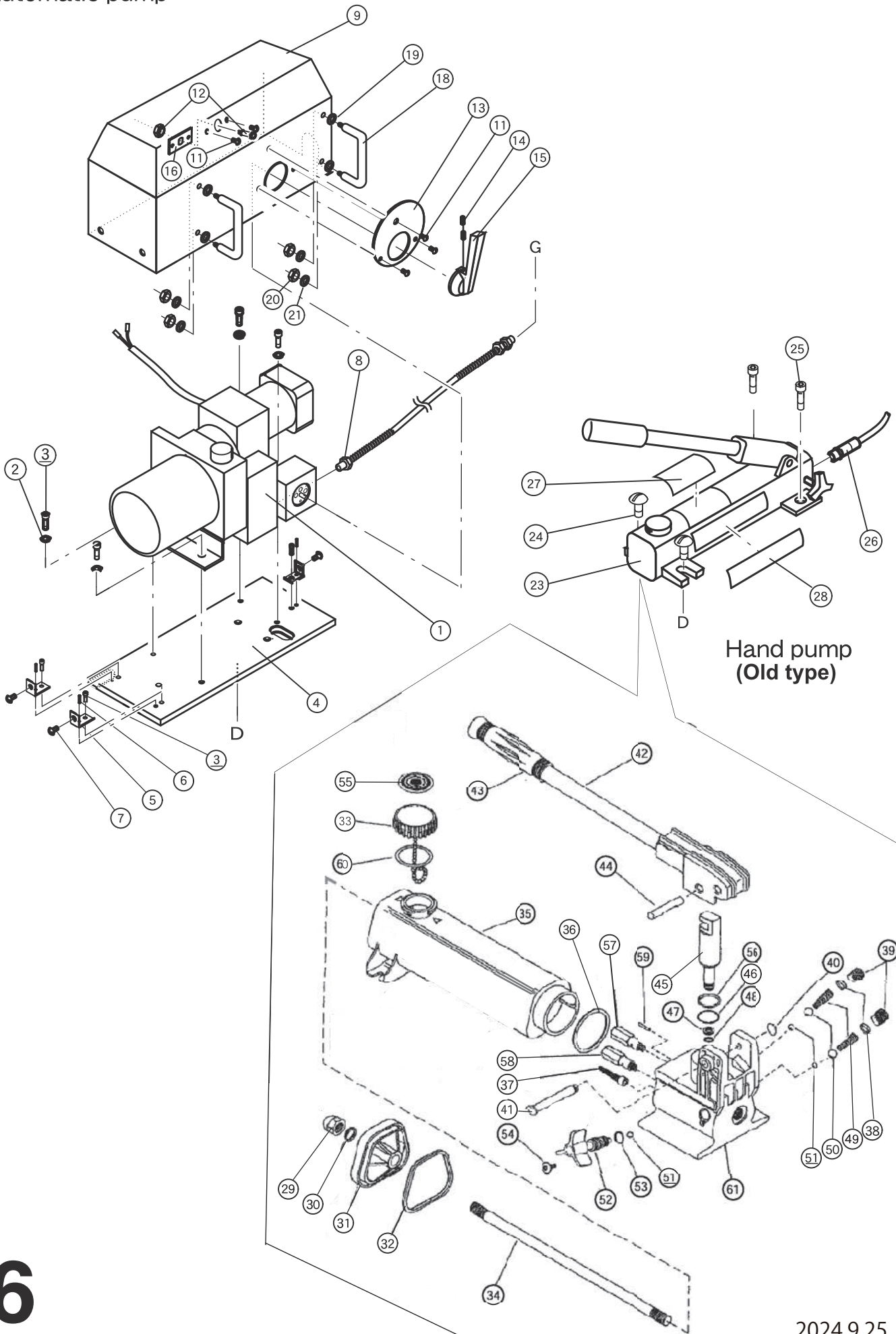

Hand pump
(Old type)

150DX -6 (Pump)-1

2024.9.25

No.	CE	Parts No.	Parts Name.	Set
			(AUTOMATIC PUMP)	
1		RJB1	Automatic pump (50Hz /100-110V)	1
1		RJB8	Automatic pump (60Hz /100-110V)	1
1		RJK6	Automatic pump (50Hz /220V)	1
2		WG06	Spring washer (M6)	4
3		W062	Socket head cap screw (M6x16)	7
4		RJK7	Pump base	1
5		RJ23	Cover fixed plate	3
6		WL34	Spring pin (3x12)	3
7		W567	Truss head screw (M6x12)	3
8		RX32	Pressure oil hose	1
9		RJK8	Pump cover	1
11		W541	Truss head screw (M4x5)	3
12		RJB5	Pilot lamp 100V-120V	1
		RJK9	Pilot lamp 220V-230V	
13		RJB6	Lever plate	1
14		W662	Socket set screw (cone) (M6x8)	2
15		RJW1	Lever handle	1
16		RJB4	Lamp plate	1
18		RJB9	Lever protector	2
19		WI81	Plain washer (M8)	8
20		WC08	Hexagon nut (M8)	4
21		WG08	Spring washer (M8)	4
			(HAND PUMP)	
23		RA73	Pump (P-142)	1
23		RA79	Pump (HP-3RX)	1
24		W567	Truss head screw (M6x12)	2
25		W063	Socket head cap screw (M6x20)	2
26		RX32	Pressure oil hose	1
27		7A12	Pump handle operation seal	1
28		7A13	Name seal	1
29		CL341055	Acorn nut	1
30			Gasket	1
31		CN402020	End cap	1
32		B1138517	Square ring	1
33		CN766950	Vent cap assembly	1
34		CL280149	Tie rod	1
35		CN782025	Reservoir	1
36			Gasket	1
37		CB981018	Filter	1
38			Spring cap	2
39		CN815006	Pipe plug	2
40			Retaining ring	1
41		CR215061	Beam pin	1
42		RP4216	Beam and handle assembly (CL915900)	1
43		RP4217	Handle grip (CL342550)	1
44		RP4218	Cross pin (P20857)	1
45		RP4219	Plunger (CN412040)	1
46		B1018803	O-ring	1
47		B1010564	Back-up washer	1
48		B1010803	O-ring	1

-to be continued-

150DX -6 (Pump)-2

2024.9.25

No.	CE	Parts No.	Parts Name.	Set
49			Spring	2
50		B1009016	5/16" Ball	2
51		B1006016	7/32" Ball	3
52		CL913900	Spindle assembly	1
53		B1007503	O-ring	1
54			Truss head machine screw	1
55				
56			Back-up washer	1
57			Bypass valve	1
58			Relief valve	1
59			Spring pin	1
60			Vent cap gasket	1
61		DA5483005	pump base	1

Hand pump (New type)

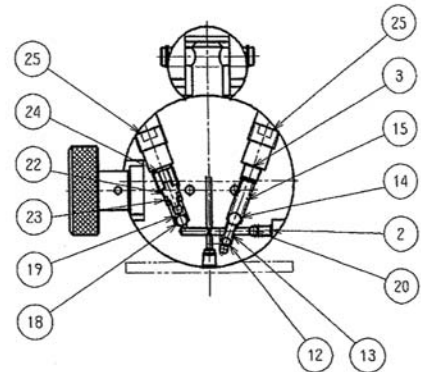
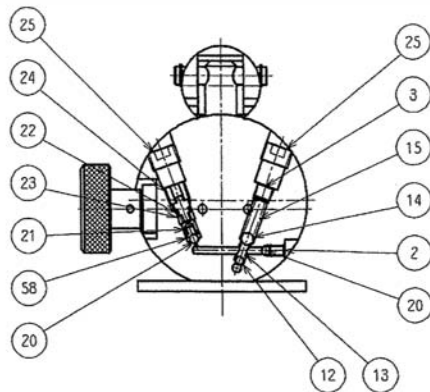
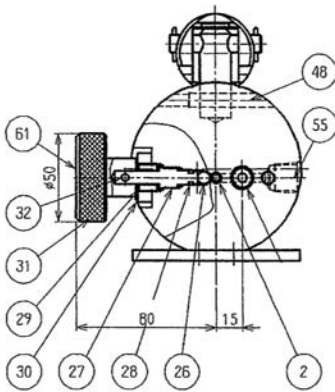
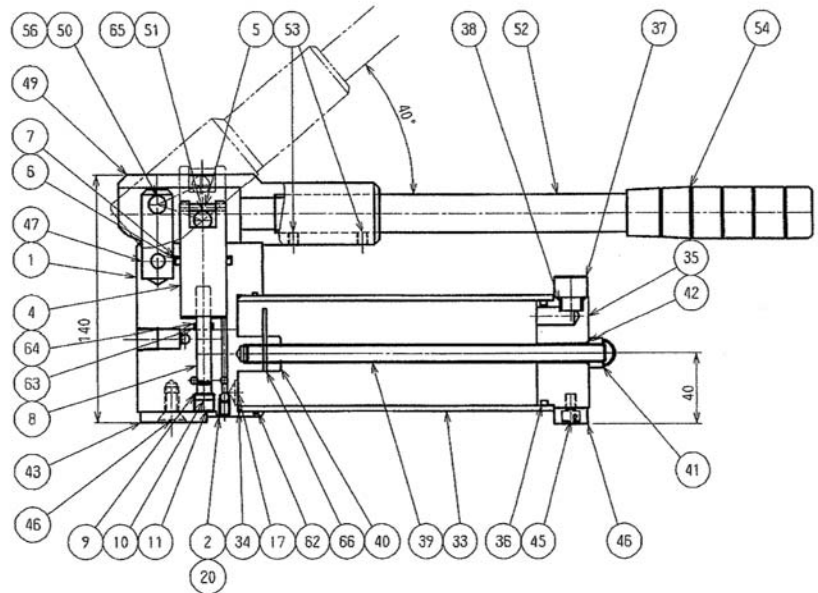
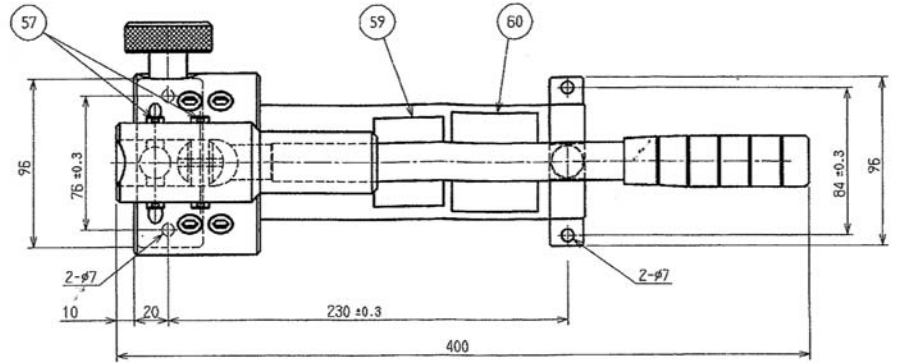

High pressure part cross section

Low pressure part cross section

150DX -7 (New Hand Pump)

2024.9.25

*A: supplied as an Assembly

No.	CE	Parts No.	Parts Name.	Set
1		NHPLG-1	Pump	A
2		NHPLG-2	Cap PT 1/16	5
3		NHPLG-3	Cap PT 1/8	2
4		NHPLG-4	Low pressure piston	A
5		NHPLG-5	Spring pin	1
6		NHPLG-6	O-ring P-26	1
7		NHPLG-7	Back up ring P-26 Bias	1
8		NHPLG-8	High pressure piston	1
9		NHPLG-9	Copper packing	1
10		NHPLG-10	High pressure cap	1
11		NHPLG-11	Push Screw	1
12		NHPLG-12	Stell ball (5.5)	2
13		NHPLG-13	Spring	2
14		NHPLG-14	Stell ball (7)	2
15		NHPLG-15	Spring	2
16			-	-
17		NHPLG-17	Suction filter	1
18		NHPLG-18	Stell ball (6)	1
19		NHPLG-19	Spring	1
20		NHPLG-20	Stell ball	1
21		NHPLG-21	Spring	1
22		NHPLG-22	Push spring	2
23		NHPLG-23	O-ring P-6	2
24		NHPLG-24	Adjustment screw	2
25		NHPLG-25	Cap screw	4
26		NHPLG-26	Stell ball (5.5)	1
27		NHPLG-27	Valve screw	A
28		NHPLG-28	O-ring P-5	1
29		NHPLG-29	Stopper screw	1
30		NHPLG-30	Lock nut	1
31		NHPLG-31	Handle	A
32		NHPLG-32	Spring pin	1
33		NHPLG-33	Oil tank	A
34		NHPLG-34	O-ring S-63	1
35		NHPLG-35	Tank end cap	A
36		NHPLG-36	O-ring G-55	1
37		NHPLG-37	refueling cap	1
38		NHPLG-38	O-ring P-11	1
39		NHPLG-39	Tank shaft	A
40		NHPLG-40	Lock nut M10	1
41		NHPLG-41	Cap nut M10	1
42		NHPLG-42	O-ring P10	1
43		NHPLG-43	Front stand	A
44		NHPLG-44	Back stand	A
45		NHPLG-45	Installation bolt M6x15 w/Hex socket screw	2
46		NHPLG-46	Installation bolt M8x15 Plate screw	2
47		NHPLG-47	fulcrum post	A
48		NHPLG-48	Parallel pin	1
49		NHPLG-49	Lever holder	A
50		NHPLG-50	Fulcrum pin 1	1
51		NHPLG-51	Fulcrum pin 2	A
52		NHPLG-52	Lever	A
53		NHPLG-53	Lock screw M6x8 Enamel	2
54		NHPLG-54	Grip	1
55		NHPLG-55	Cap PT3/8	A
56		NHPLG-56	Metal bush	4
57		NHPLG-57	Roll pin	1
58		NHPLG-58	Ball retainer	A
59		NHPLG-59	Warining seal	A
60		NHPLG-60	Air valve operation method label	1
61		NHPLG-61	Opening and shutting direction seal	1
62		NHPLG-62	O-ring S-65	1
63		NHPLG-63	O-ring P-5	1
64		NHPLG-64	Back up ring P-5	1

REX

REX INDUSTRIES CO., LTD.

Overseas Sales Dept. (Head Office & Factory):

1-9-3, Hishiyahigashi, Higashi Osaka 578-0948, Japan

Tel.: +81 - (0)72 - 961 - 9820 Fax.: +81 - (0)72 - 961 - 9878

URL <https://www.rexind.co.jp>