

**REX**  
ELECTRIC PIPE THREADING MACHINE

# NS25A Series

## Parts List

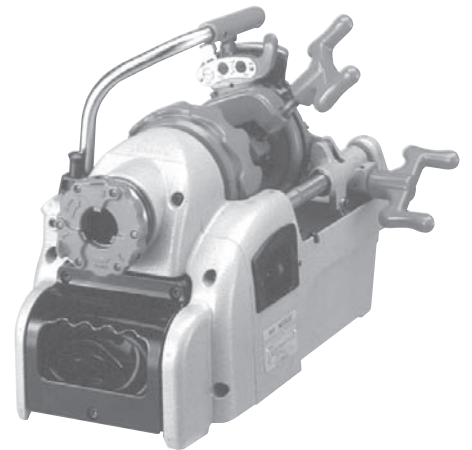
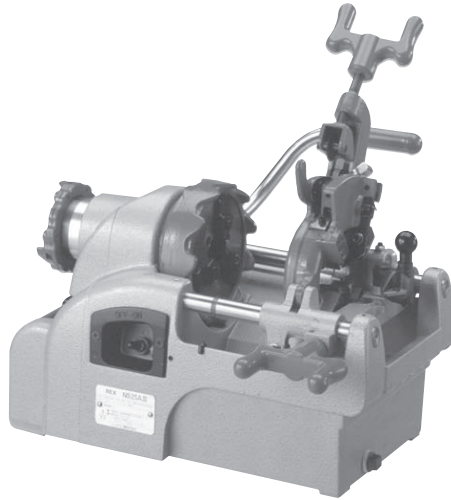

### CONTENTS

1. Base
2. Main Shaft, Motor
3. Carriage
4. Cutter Reamer
5. Motor

**REX**

# NS25A Series

## 1. Base

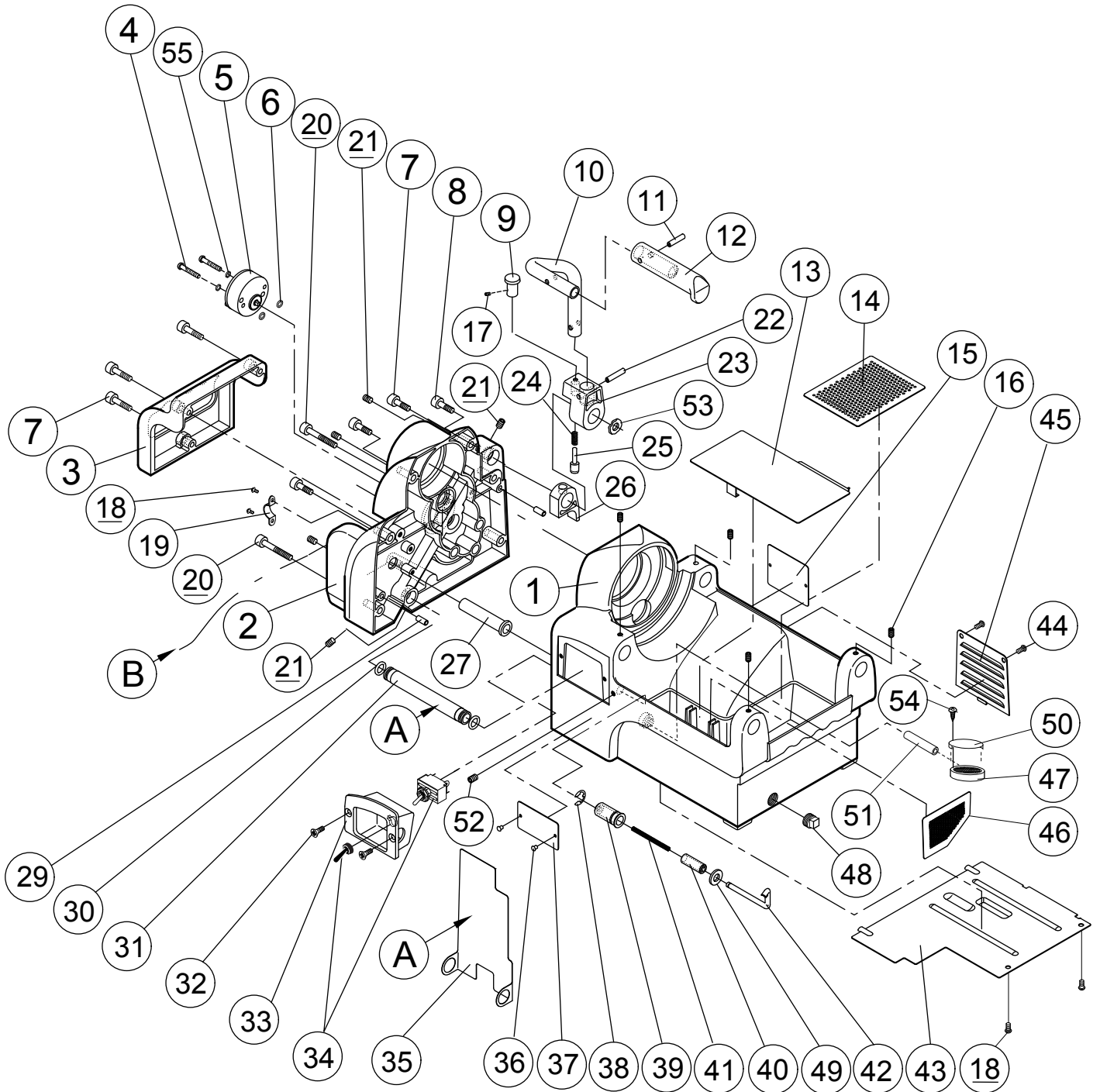

Page	Item	Page title	Part No.	Part Name	Spec	Q'ty	Remarks
1	1	1.Base.	MY01	Base		1	
1	2	1.Base.	MY02	Transmission case		1	
1	3	1.Base.	MY03	Rear cover		1	
1	4	1.Base.	W256	Pan head machine screw	M5×30	2	
1	5	1.Base.	TY37C	Gear pump		1	
1	6	1.Base.	Z507	O-ring	P7	2	
1	7	1.Base.	W06B	Hex socket head cap screw	M6×25	5	
1	8	1.Base.	W065	Hex socket head cap screw	M6×30	2	
1	9	1.Base.	MYA3	Carrying handle movable block fix pin		1	Old No.MY30C
1	10	1.Base.	MY27	Carrying handle		1	
1	11	1.Base.	WL6B	Roll pin	6×25	1	
1	12	1.Base.	MY28	Carrying handle grip		1	
1	13	1.Base.	MY18	Scrap receiver	large	1	
1	14	1.Base.	MY19	Scrap receiver	small	1	
1	15	1.Base.	MY99	Plate (for changing carbon brushes)		1	
1	16	1.Base.	W663	Hex socket set screw	M6×10 cone point	4	
1	17	1.Base.	W645	Hex socket set screw	M4×5 cone point	1	Old No. #0025(M4X4)
1	18	1.Base.	W251	Pan head machine screw	M5×8	4	
1	19	1.Base.	7098	Saddle	C15	1	
1	20	1.Base.	W069	Hex socket head cap screw	M6×55	2	
1	21	1.Base.	WA43	Taper plug	R1/8	5	
1	22	1.Base.	WL65	Roll pin	6×28	1	
1	23	1.Base.	MYA1	Carrying handle movable block		1	
1	24	1.Base.	MY32	Carrying handle fixed spring		1	
1	25	1.Base.	MYA4	Carrying handle fixed pin guide		1	
1	26	1.Base.	MYA2	Carrying handle fixed block		1	
1	27	1.Base.	7021	D5.8 Cord bush		1	Old No. TY25
1	28	1.Base.	MY2A	Cabtyre cord for motor	220V	1	
1	28	1.Base.	MY2B	Cabtyre cord for motor	115V	1	
1	28	1.Base.	Z992	Cabtyre cord for motor	WH	1	
1	29	1.Base.	WN09	Parallel pin	6×15	2	
1	30	1.Base.	Z5S1	O-ring	P12.5	2	
1	31	1.Base.	MY92	Oil pipe		1	
1	32	1.Base.	W346	Oval head machine screw	M5×10	2	
1	33	1.Base.	MY21	Switch case		1	
1	34	1.Base.	MY20C	Switch		1	
1	35	1.Base.	MY96	Wiring protecting cover		1	
1	36	1.Base.	WN34	Rivet	#4×5	2	
1	37	1.Base.	MY89	Name plate	WH	1	not for sale
1	37	1.Base.	MY88	Name plate	for 25A3 self-open	1	not for sale
1	37	1.Base.	MY8A	Name plate	for 25A manual-open	1	not for sale
1	38	1.Base.	WY04	Snap ring	code 4	1	
1	39	1.Base.	MY39	Spring receptacle B		1	
1	40	1.Base.	MY40	Spring receptacle C		1	
1	41	1.Base.	MY43	Spring		1	
1	42	1.Base.	MY41	Adjustment bar		1	
1	43	1.Base.	MY25C	Bottom cover		1	
1	44	1.Base.	W556	Truss machine screw	M5×10	2	
1	45	1.Base.	MY23C	Side cover <b>**discontinued</b>		1	
1	46	1.Base.	MY24	Tank partition		1	
1	47	1.Base.	N048	Strainer		1	
1	48	1.Base.	WA46	Drain Plug	R1/2#	1	
1	49	1.Base.	WI42	Flat washer	4	1	
1	50	1.Base.	HY96	Strainer cover <b>**discontinued</b>		1	
1	51	1.Base.	0410-105	Tank Hose	105mm/Red	1	#0026
1	52	1.Base.	W662	Hex socket set screw	M6×8 Cone point	1	
1	53	1.Base.	WH20	Wave washer	WW-20	1	
1	54	1.Base.	WA55	Pan head tapping screw	M5×8	1	
1	55	1.Base.	WG05	Spring washer	M5 silver	2	



Page	Item	Page title	Part No.	Part Name	Spec	Q'ty	Remarks
2	1	2. Main Shaft, Motor	MY04	Blue Motor <b>**discontinued</b>	100V	1	Blue Motor
2	1	2. Main Shaft, Motor	MY04T	Black Motor	100V	1	Black Motor
2	1	2. Main Shaft, Motor	MY9AC	Blue Motor <b>**discontinued</b>	115V	1	Blue Motor for WH
2	1	2. Main Shaft, Motor	MY9AT	Black Motor	115V	1	Black Motor for WH
2	1	2. Main Shaft, Motor	MY9B	Blue Motor <b>**discontinued</b>	220V	1	Blue Motor
2	1	2. Main Shaft, Motor	MY9BT	Black Motor	220V	1	Black Motor
2	7	2. Main Shaft, Motor	MY05C	First gear assembly		1	
2	8	2. Main Shaft, Motor	MY07C	Second gear assembly		1	
2	9	2. Main Shaft, Motor	02MY	Main shaft with gear		1	
2	10	2. Main Shaft, Motor	MY0A	Bearing	6009zz	2	
2	11	2. Main Shaft, Motor	S374	Bearing	6000zz	1	
2	12	2. Main Shaft, Motor	S373	Miniature bearing	608zz	1	
2	13	2. Main Shaft, Motor	J300	Bearing	6001zz	1	
2	14	2. Main Shaft, Motor	MY0B	Bearing	6904zz	1	
2	15	2. Main Shaft, Motor	MY16	Hand wheel		1	
2	16	2. Main Shaft, Motor	W06K	Hex socket head cap screw	M6×45GR MecSeal	3	
2	17	2. Main Shaft, Motor	MY87	Insulation sponge 2		1	
2	18	2. Main Shaft, Motor	W068	Hex socket head cap screw	M6×45	3	
2	19	2. Main Shaft, Motor	KY04	Complete chuck assembly		1 set	
2	20	2. Main Shaft, Motor	TYH0	Chuck body		1	
2	21	2. Main Shaft, Motor	H0CJS	Chuck jaw set	RT-NS	1 set	3pcs each/set incl. G0NS
2	21	2. Main Shaft, Motor	H1CJS	Chuck jaw set	RT-RT	1 set	3pcs each/set incl.
2	22	2. Main Shaft, Motor	G0NS	Chuck jaw insert set		1 set	3pcs each/set
2	23	2. Main Shaft, Motor	MY17	Complete rear chuck assembly		1 set	
2	24	2. Main Shaft, Motor	W24C	Pan head machine screw	M4×12 black	6	
2	25	2. Main Shaft, Motor	MYSS	Rear chuck jaw		1 set	3pcs/set
2	26	2. Main Shaft, Motor	MYS1	Rear chuck receptacle		1	
2	27	2. Main Shaft, Motor	MYS3	Rear scroll		1	
2	28	2. Main Shaft, Motor	MYS2	Rear chuck cover		1	
2	29	2. Main Shaft, Motor	WW45	Snap ring	out side 45	1	
2	30	2. Main Shaft, Motor	WM52	Grooved pin	5x14	3	
2	31	2. Main Shaft, Motor	TYS0	Chuck scroll		1	

# NS25A Series

## 3. Carriage

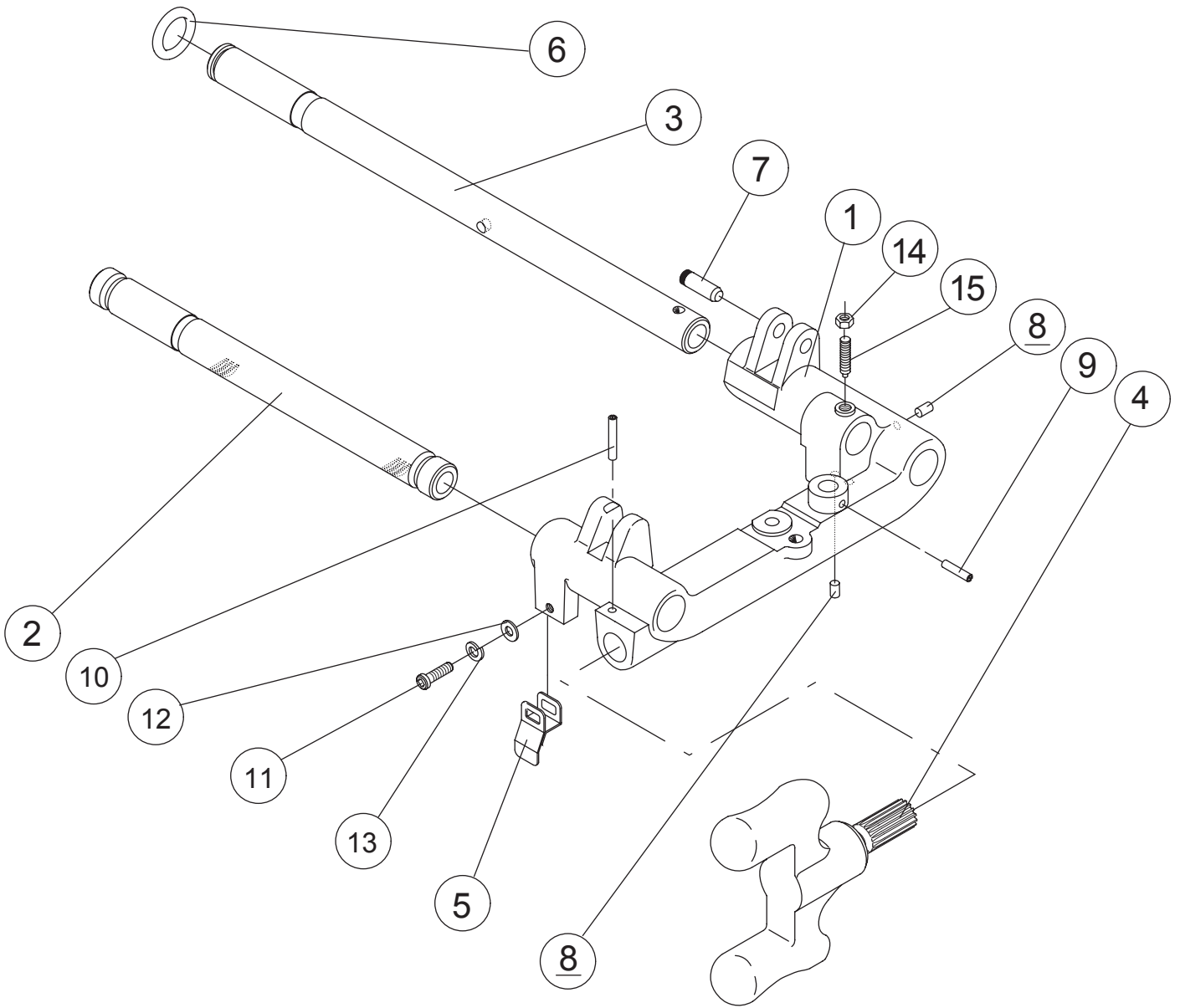

Page	Item	Page title	Part No.	Part Name	Spec	Q'ty	Remarks
3	1	3. Carriage	MY33	Carriage		1	
3	2	3. Carriage	MY14	Carriage support bar A		1	
3	3	3. Carriage	MY15	Carriage support bar B		1	
3	4	3. Carriage	MY34	Carriage handle		1	
3	5	3. Carriage	MY44	Size adjustment plate		1	
3	6	3. Carriage	Z515	O-ring	P15	1	
3	7	3. Carriage	HY62	Cutter arm stop pin		1	
3	8	3. Carriage	HY49	Oil cap		2	
3	9	3. Carriage	WL45	Roll pin	φ4×18	1	
3	10	3. Carriage	WL47	Roll pin	φ4×25	1	
3	11	3. Carriage	W052	Hex socket head cap screw	M5×10	1	
3	12	3. Carriage	W152	Flat washer	5	1	
3	13	3. Carriage	WG5A	Spring washer	5 Black	1	
3	14	3. Carriage	WD06	Jam nut	M6	1	
3	15	3. Carriage	W865	Hex-socket set screw	M6×12	1	

# NS25A Series

## 4. Cutter Reamer

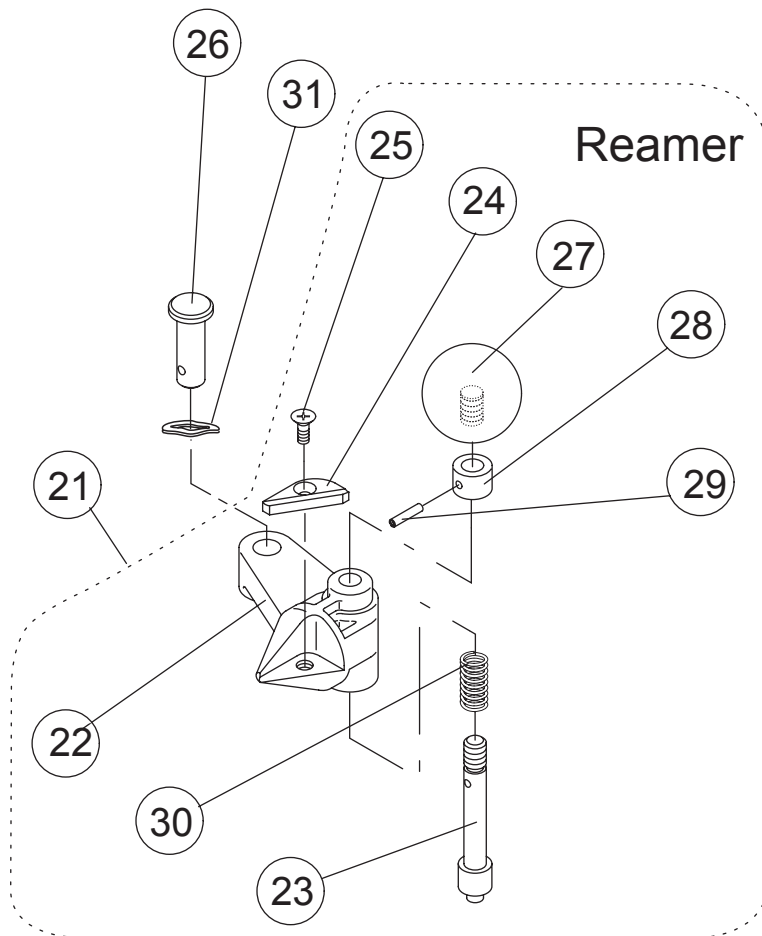
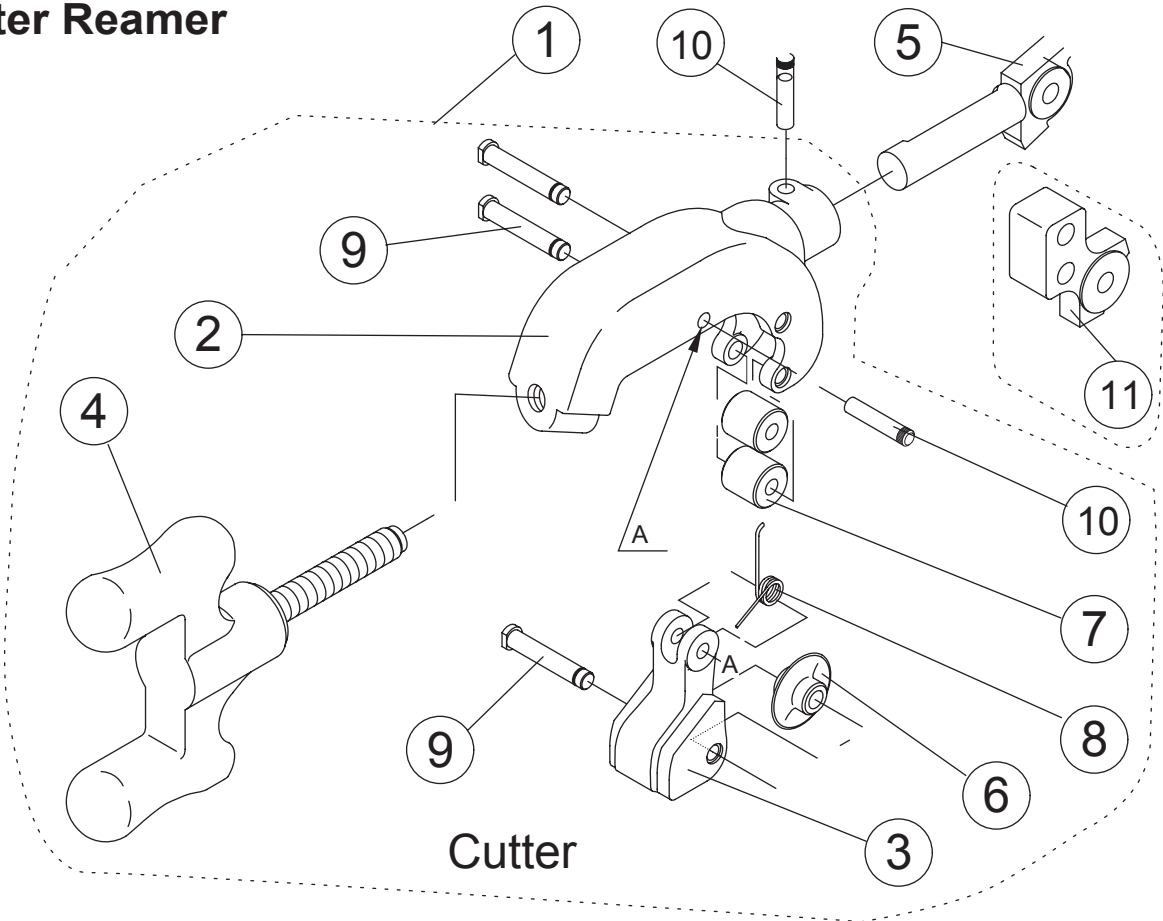

Page	Item	Page title	Part No.	Part Name	Spec	Q'ty	Remarks
4	1	4. Cutter Reamer	0MCU1S	Complete cutter assembly		1	
4	1	4. Cutter Reamer	0MCU2S	Complete cutter assembly	SUS	1	
4	2	4. Cutter Reamer	MY45	Cutter frame		1	
4	3	4. Cutter Reamer	MY46	Cutter guide		1	
4	4	4. Cutter Reamer	MY48	Cutter handle		1	
4	5	4. Cutter Reamer	MY47	Cutter arm		1	
4	6	4. Cutter Reamer	135070	Cutter wheel		1	see Product List
4	6	4. Cutter Reamer	135071	Cutter wheel	SUS	1	see Product List
4	7	4. Cutter Reamer	HY57C	Cutter roller <b>**discontinued</b>		2	
4	8	4. Cutter Reamer	HY63	Spring		1	
4	9	4. Cutter Reamer	CT07	Cutter pin A		3	
4	10	4. Cutter Reamer	HY61	Cutter frame pin		2	
4	11	4. Cutter Reamer	MY93	Cutter arm for carbide cutter		1	
4	21	4. Cutter Reamer	0MRM1S	Complete reamer assembly		1	
4	22	4. Cutter Reamer	MY50	Reamer body		1	
4	23	4. Cutter Reamer	MY54	Reamer fixing shaft		1	
4	24	4. Cutter Reamer	MY52	Reamer blade		1	
4	25	4. Cutter Reamer	W345	Flat head machine screw	M4×8	1	
4	26	4. Cutter Reamer	MY53	Reamer rotation shaft		1	
4	27	4. Cutter Reamer	MY56	Reamer grip		1	
4	28	4. Cutter Reamer	MY55	Reamer fixing shaft collar		1	
4	29	4. Cutter Reamer	WL3A	Roll pin	3×14	1	
4	30	4. Cutter Reamer	MY94	Reamer fixing shaft spring		1	
4	31	4. Cutter Reamer	WH12	Wave washer	#WW-12	1	

# NS25A Series

## 5. Motor

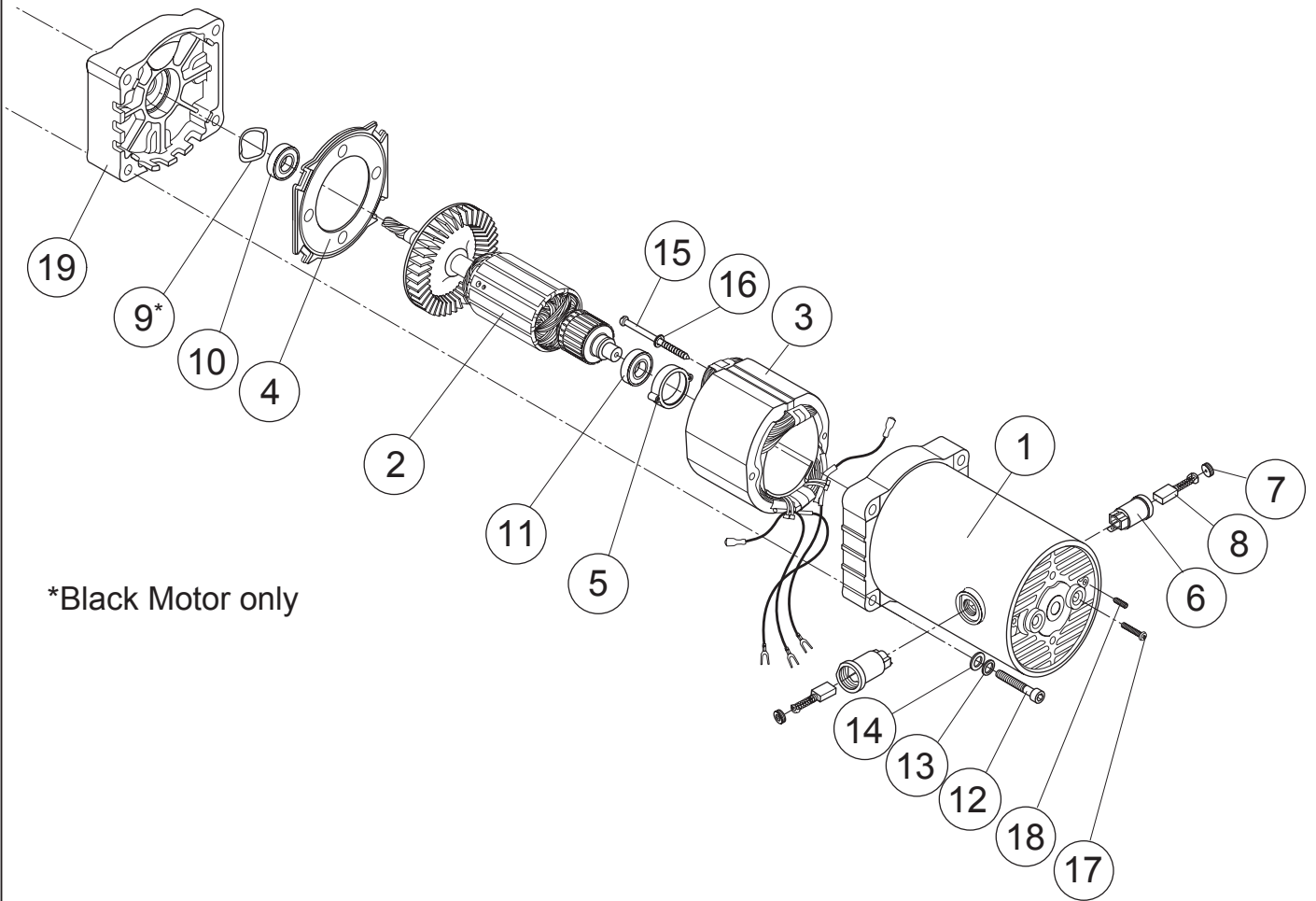

Page	Item	Page title	Part No.	Part Name	Spec	Q'ty	Remarks
5	1	5. Motor	MYM7	Motor case <b>**discontinued</b>		1	for Blue Motor
5	1	5. Motor	G2M25	Motor case		1	for Black Motor
5	2	5. Motor	MYM1	Armature assembly <b>**discontinued</b>	100V	1	for Blue Motor
5	2	5. Motor	G2M01	Armature assembly	100V	1	for Black Motor
5	2	5. Motor	MYM32	Armature assembly	115V	1	for Blue Motor
5	2	5. Motor	G2M02	Armature assembly	115V	1	for Black Motor
5	2	5. Motor	MYM34	Armature assembly	220V	1	for Blue Motor
5	2	5. Motor	G2M04	Armature assembly	220V	1	for Black Motor
5	3	5. Motor	MYM5	Stator assembly <b>**discontinued</b>	100V	1	for Blue Motor
5	3	5. Motor	G2M05	Stator assembly	100V	1	for Black Motor
5	3	5. Motor	MYM36	Stator assembly	115V	1	for Blue Motor
5	3	5. Motor	G2M06	Stator assembly	115V	1	for Black Motor
5	3	5. Motor	MYM38	Stator assembly	220V	1	for Blue Motor
5	3	5. Motor	G2M08	Stator assembly	220V	1	for Black Motor
5	4	5. Motor	MYM18	Fan casing		1	for Blue Motor
5	4	5. Motor	G2M27	Fan casing		1	for Black Motor
5	5	5. Motor	MYM21	Bearing casing <b>**discontinued</b>		1	for Blue Motor
5	5	5. Motor	G2M29	Bearing casing		1	for Black Motor
5	6	5. Motor	MYM3	Carbon brush holder <b>**discontinued</b>		2	for Blue Motor
5	6	5. Motor	G2M16	Carbon brush holder		2	for Black Motor
5	7	5. Motor	MYM4	Carbon brush cap		2	for Blue Motor
5	7	5. Motor	G2M17	Carbon brush cap		2	for Black Motor
5	8	5. Motor	MYM2	Carbon brush	100-220V	1 set	2pcs/set
5	9	5. Motor	#0036	Wave washer	19.5x24.8x3.2	1	for Black Motor only
5	10	5. Motor	S374	Ball Bearing	6000ZZ	2	
5	11	5. Motor	KM09	Ball Bearing	629ZZ	1	
5	12	5. Motor	W066	Hex socket head cap screw	M6x35	4	
5	13	5. Motor	WG6A	Spring washer	M6Black	4	
5	14	5. Motor	WI61C	Flat washer	M6Black	4	
5	15	5. Motor	#0037	Tapping screw	Half thread M5x60	2	
5	16	5. Motor	WG05	Spring washer	M5	2	
5	17	5. Motor	W244	Pan head machine screw	M4x15Black	2	
5	18	5. Motor	#0014	Hex socket set screw	M5×10 Cup Point	2	
5	19	5. Motor	MYM19	Inner cover <b>**discontinued</b>		1	for Blue Motor
5	19	5. Motor	G2M30	Inner cover		1	for Black Motor



## **REX INDUSTRIES CO., LTD.**

**Overseas Sales Dept. (Head Office & Factory):**

**1-9-3, Hishiyahigashi, Higashi Osaka 578-0948, Japan**

**Tel.: +81 - (0)72 - 961 - 9820 Fax.: +81 - (0)72 - 961 - 9878**

**URL** <http://www.rexind.co.jp>