

Manual Open Die Head for W,R50A 1/2 - 2

295680 :
1/2-2 BSPT/NPT

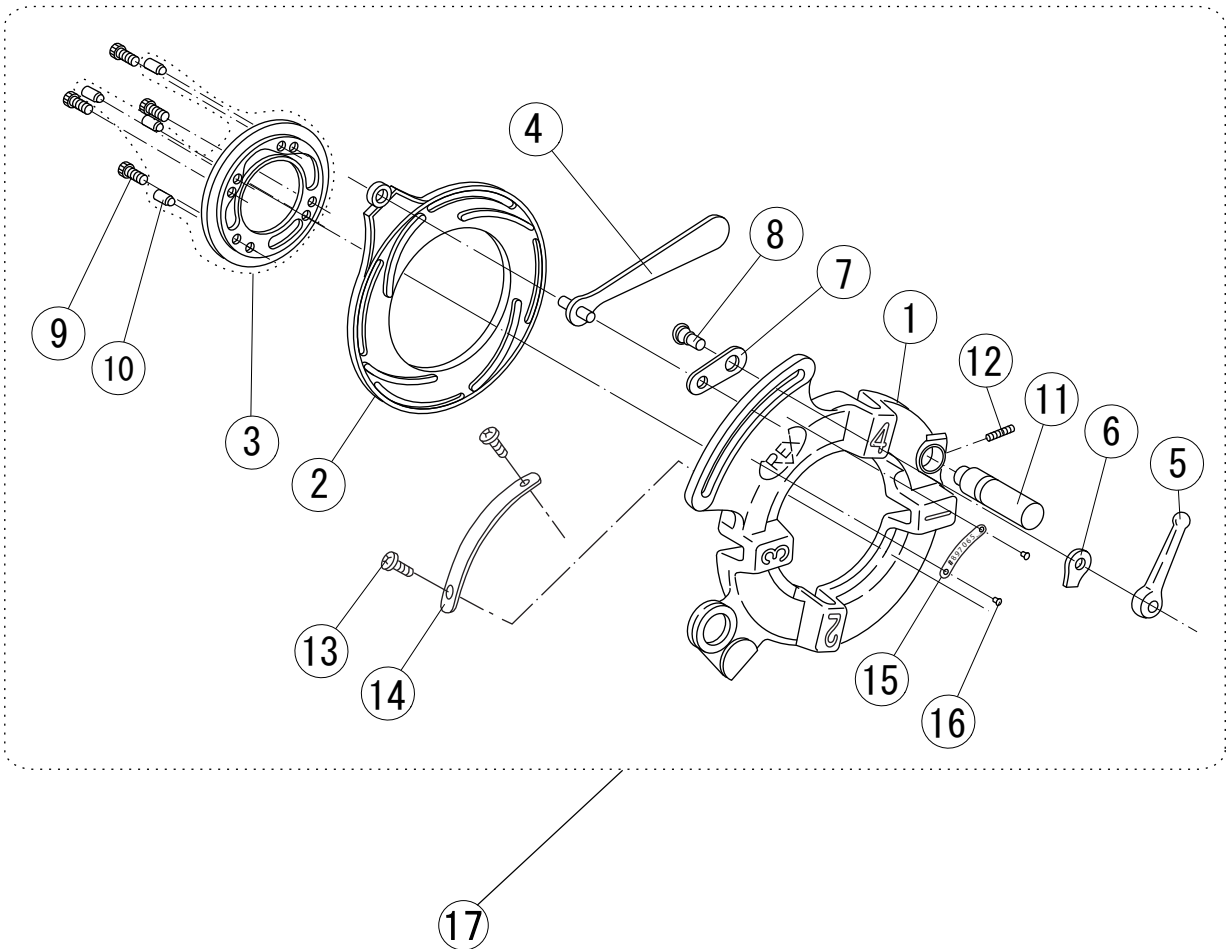

MDH50A-R-type_exp Manual Die Head for R50A (1/2-2")

295680

2006/5/15

Drawings & NO.	REX Parts	Parts Name	Spec.	Q'ty	Remarks
1	RH01	Die Head Body		1	
2	RH02	Cam Plate		1	
3	N703	Retaining Ring with Dies Notch		1	
4	2361	Eccentric Handle		1	
5	2377	Lever Nut		1	
6	2381	Eccentric Washer		1	
7	2371	Eccentric Link		1	
8	2386	Eccentric Screw		1	
9	W062	Socket Head Cap Screw	(M6×16)	4	
10	G860	Dies Notch		4	
11	N676	Die Head Post		1	
12	W661	Hex Socket Set Screw	(M6×6: cone point)	1	
13	RH03	Size Plate		1	
14	W541	Truss Screw	(M4×5)	2	
15	RH04	No. Plate		1	
16	WN34	Rivet	(#4×5)	2	