

MANTIS Series

Greatly improved operability, safety and transportability.



For 4" PIPE

Chain Vice

MANTIS 125	8A-100A (1/2"-4")
Code No.	475140
Model	MANTIS XB125
Cutting capacity	90° ROUND PIPE Φ125/SQUARE PIPE 100
Motor	Single phase 220 V (50/60 Hz), Split-phase Induction motor 200 W, with overload protection
Pulley speed (rpm)	70 (50 Hz), 84 (60 Hz)
Dimensions (mm)	L780 x W340 x H335
Weight (kg)	33
Standard accessories	14-tooth HSS blade (x1)(475312), Hex key wrench 5 mm

Flat Vice

MANTIS 120A	8A-100A (1/2"-4")
Code No.	475142
Model	MANTIS XB120A
Cutting capacity	90° ROUND PIPE Φ120/SQUARE PIPE 105 45° ROUND PIPE Φ50/SQUARE PIPE 50
Motor	Single phase 220 V (50/60 Hz), Split-phase Induction motor 200 W, with overload protection
Pulley speed (rpm)	70 (50 Hz), 84 (60 Hz)
Dimensions (mm)	L780 x W340 x H335
Weight (kg)	35
Standard accessories	14-tooth HSS blade (x1)(475312), Hex key wrench 5 mm, Hex socket wrench 17 mm



475142

For 6" PIPE

Lightest in its class! Two actions in one machine!

We've brought you safety, we've brought you ease of use, now we bring you a new type of machine in the MANTIS series. Just change the vice for double the action!

Chain Vice



CHAIN VICE UNIT
475190

Flat Vice



FLAT VICE UNIT
475192



4751S1

MANTIS 180WS	8A-150A (1/2"-6")
Code No.	4751S1, 4751S2 (CE)
Model	MANTIS XB180WS
Cutting capacity	90° ROUND PIPE Φ180/SQUARE PIPE 150
Motor	Single phase 220 V (50/60 Hz), Split-phase Induction motor 250 W, with overload protection
Pulley speed (rpm)	70 (50 Hz), 84 (60 Hz)
Dimensions (mm)	L865 x W355 x H415
Weight (kg)	37
Standard accessories	14-tooth HSS blade (x1)(475211), Hex key wrench 5 mm

MANTIS 180WA 8A-150A (1/2"-6")

Code No.	4751A1, 4751A2 (CE)
Model	MANTIS XB180WA
Cutting capacity	90° ROUND PIPE Φ180/SQUARE PIPE 150 45° ROUND PIPE Φ80/SQUARE PIPE 80
Motor	Single phase 220 V (50/60 Hz), Split-phase Induction motor 250 W, with overload protection
Pulley speed (rpm)	70 (50 Hz), 84 (60 Hz)
Dimensions (mm)	L865 x W355 x H415
Weight (kg)	44
Standard accessories	14-tooth HSS blade (x1)(475211), Hex key wrench 5 mm, Hex socket wrench 17 mm



4751A1

NEW

MANTIS Series

MANTIS 270A

8A-250A (1/2"-10")

Among the lightest and most portable of large Band Saws!
Does just about everything you need to do at site!

The latest model in the Mantis range adds a new dimension to your work. Hydraulic cylinder inside base unit allows variable adjustment of the frame lowering speed.

Features (Letters A to F refer to diagram below)

- Handles up to 10" pipe
- 4 wheels built in for great portability - **A**
- Lightest in its class
- Oil-free cutting
- Hydraulic damper and spring allows smooth adjustment of cutting speed - **B**
- Cuts at angles from 0° to 45°
- Lets you replace the blade from the front (same as Mantis 180W) - **C**
- Built-in brush for plastic waste (same as Mantis 180W) - **D**
- Reset switch for when overload protection kicks in - **E**
- Clamp to keep pipe in place - **F**

For 10" PIPE



Flat Vice Only

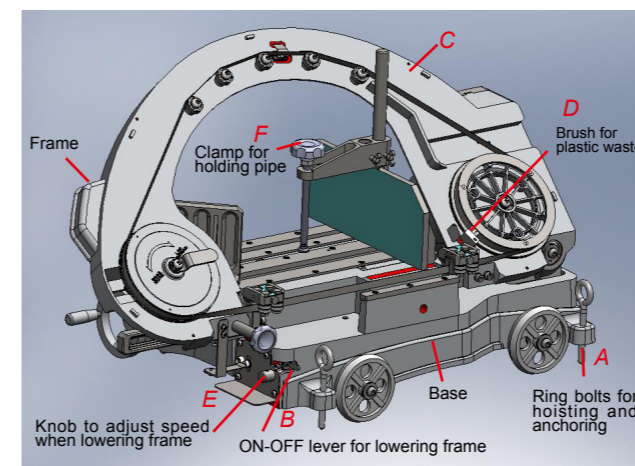

MANTIS 270A

Code No.	4751C1
Model	MANTIS XB270A
Cutting capacity	90° ROUND PIPE Φ270/SQUARE PIPE 250 45° ROUND PIPE Φ170/SQUARE PIPE 150
Motor	Single phase 220 V (50/60 Hz), Split-phase Induction motor 250 W, with overload protection
Pulley speed (rpm)	70 (50 Hz), 84 (60 Hz)
Dimensions (mm)	L990 x W510 x H600
Weight (kg)	80
Standard accessories	14-tooth HSS blade (x1)(475270) Spanner for adjustment of vice angle, Wrench (19 mm) Hex key wrench 8 mm

Optional accessories	Cutting-length guide (475196), 14-tooth HSS blade, Pipe support for 270A (475129) Coming soon!
----------------------	---

Blades

Code No.	475270
Material	HSS (Bimetal)
No. of teeth (teeth/inch)	14
No. of blades included	5

Use: Cutting Steel & Stainless Steel materials

